



TOE-S616-40.8

TRANSISTOR INVERTER

# Varispeed-616HII™

380 TO 460 V, 220 TO 300 kW (300 TO 400 HP), 300 TO 400 kVA

## INSTRUCTION MANUAL

Before initial operation  
read these instructions  
thoroughly, and retain  
for future reference

When properly installed, operated and maintained, this equipment will provide a lifetime of service. It is mandatory that the person who operates, inspects, or maintains this equipment thoroughly read and understand this manual, before proceeding.

This manual applies to VS-616HII Model CIMR-H220B and -H300B.

The VS-616HII Drive is an AC variable speed drive system for high-precision variable speed applications. It basically consists of a three-phase squirrel-cage induction motor, a VS-616HII controller (VS-616HII), an operator control station, and optional control units. This manual primarily describes VS-616HII, but contains basic information for operator control station as well. For details of the operation of individual units, refer to their respective manuals.

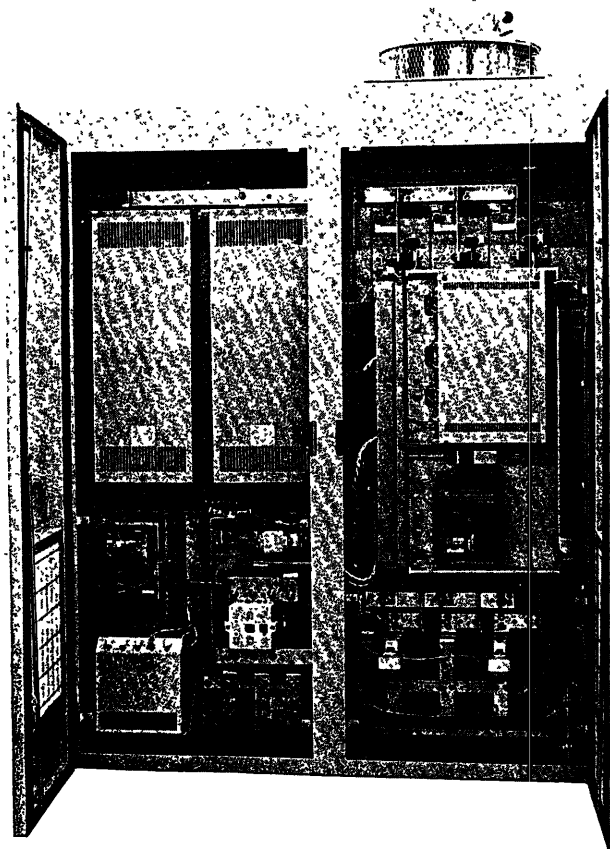

VS-616HII Inverter  
400 V, 400 kVA

## CONTENTS

<p><b>1. RECEIVING</b> 5</p> <p><b>2. VS-616HII FUNCTIONAL DESCRIPTION</b> 6</p> <p>2.1 VS-616HII Functional Block Diagram and Major Control Component Layout 6</p> <p>2.2 Circuit Operational Description 8</p> <p>2.2.1 Main Circuit 8</p> <p>2.2.2 Control Circuit 8</p> <p>2.2.3 Protective Circuits 9</p> <p><b>3. INSTALLATION</b> 9</p> <p>3.1 Location 9</p> <p>3.2 Positioning 10</p> <p><b>4. WIRING</b> 11</p> <p>4.1 Interconnections 11</p> <p>4.2 Molded-Case Circuit Breaker (MCCB) and Power Supply Magnetic Contactor (MC) 12</p> <p>4.3 Surge Absorber 12</p> <p>4.4 Wire Size 12</p> <p>4.5 Wiring Instructions 13</p> <p>4.5.1 Control Circuit 13</p> <p>4.5.2 Main Circuit 13</p> <p>4.5.3 Grounding 14</p> <p><b>5. TEST RUN</b> 15</p> <p>5.1 Checks Before Test Run 15</p> <p>5.2 Presetting and Adjustment Before Test Run 15</p> <p>5.3 Trial Operation/Test Run 21</p> <p>5.3.1 Use of Analog Operator Model JVOP-72 (optional) 22</p> <p>5.3.2 Use of Digital Operator Model JVOP-71 (optional) 23</p> <p>5.3.3 Use of VS Operator Model JVOP-65 (optional) 24</p> <p>5.4 Frequency Meter Calibration 25</p> <p><b>6. OPERATION AT LOAD</b> 25</p>	<p><b>7. MAINTENANCE</b> 26</p> <p><b>8. FAILURE INDICATION AND DETAILS</b> 27</p> <p><b>9. TROUBLESHOOTING</b> 28</p> <p>9.1 Measuring Point and Instrument 28</p> <p>9.2 Troubleshooting for Motor Symptom 29</p> <p>9.3 Troubleshooting for Failure Indications 31</p> <p><b>APPENDIX 1 VS-616HII RATINGS AND SPECIFICATIONS</b> 36</p> <p><b>APPENDIX 2 TERMINAL FUNCTIONS</b> 37</p> <p><b>APPENDIX 3 INTERNAL CIRCUIT AND INTERCONNECTION DIAGRAMS</b> 38</p> <p>A3-1 VS-616HII Internal Circuit 38</p> <p>A3-2 Interconnection Diagrams for VS-616HII Applications 39</p> <p><b>APPENDIX 4 VS-616HII OPTIONAL AND AUXILIARY UNITS</b> 48</p> <p>A4-1 VS-616HII Optional Units 48</p> <p>A4-2 VS-616HII Auxiliary Units 49</p> <p><b>APPENDIX 5 CHECKING OF DIODE AND TRANSISTOR MODULES</b> 50</p> <p>A5-1 Diode Module 50</p> <p>A5-2 Transistor Module 50</p> <p><b>APPENDIX 6 PARTS REPLACEMENT</b> 51</p> <p>A6-1 Replacement of Control PC Board 51</p> <p>A6-2 Replacement of Base Drive PC Board 51</p> <p>A6-3 Replacement of Diode 52</p> <p>A6-4 Replacement of Transistor Module 53</p> <p>A6-5 Replacement of Main Circuit Fuse 54</p> <p>A6-6 Replacement of Cooling Fan 54</p> <p><b>APPENDIX 7 RENEWAL PARTS</b> 55</p>
--	---

## INDEX

Subject	Chapter	Section	Page
<b>A</b> ANALOG OPERATOR MODEL JVOP-72 (OPTIONAL), USE OF	5	5.3.1	22
Auxiliary Units, VS-616HII	APPENDIX 4	A4-2	49
<b>B</b> Before Test Run, Checks	5	5.1	15
BLOCK AND INTERCONNECTION DIAGRAMS	APPENDIX 3		38
<b>C</b> CIRCUIT OPERATIONAL DESCRIPTION	2	2.2	8
Control Circuit	2	2.2.2	8
Control PC Board, Replacement of	APPENDIX 6	A6-1	51
Cooling Fan, Replacement of	APPENDIX 6	A6-6	54

## INDEX (Cont'd)

Subject	Chapter	Section	Page
<b>D</b> Digital Operator Model JVOP-71 (Optional) (Fig. 17), Use of . . . . .	5 . . . . .	5.3.2 . . . . .	23
Diode Module . . . . .	APPENDIX 5 . . . . .	A5-1 . . . . .	50
Diode, Replacement of . . . . .	APPENDIX 6 . . . . .	A6-3 . . . . .	52
<b>F</b> FAILURE INDICATION AND DETAILS . . . . .	8 . . . . .		27
Frequency Meter Calibration . . . . .	5 . . . . .	5.4 . . . . .	25
Functional Block Diagram and Major Control Component Layout, VS-616HII . . . . .	2 . . . . .	2.1 . . . . .	6
FUNCTIONAL DESCRIPTION, VS-616HII . . . . .	2 . . . . .		6
<b>I</b> INSTALLATION . . . . .	3 . . . . .		9
Internal Circuit, VS-616HII . . . . .	APPENDIX 3 . . . . .	A3-1 . . . . .	38
Interconnection Diagrams for VS-616HII Applications . . . . .	APPENDIX 3 . . . . .	A3-2 . . . . .	39
Interconnections . . . . .	4 . . . . .	4.1 . . . . .	11
<b>L</b> Location . . . . .	3 . . . . .	3.1 . . . . .	9
<b>M</b> Main Circuit . . . . .	2 . . . . .	2.2.1 . . . . .	8
Main Circuit Fuse, Replacement of . . . . .	APPENDIX 6 . . . . .	A6-5 . . . . .	54
<b>MAINTENANCE</b> . . . . .	7 . . . . .		26
Measuring Point and Instrument . . . . .	9 . . . . .	9.1 . . . . .	28
Molded-Case Circuit Breaker (MCCB) and Power Supply Magnetic Contactor (MC) . . . . .	4 . . . . .	4.2 . . . . .	12
<b>O</b> OPERATION AT LOAD . . . . .	6 . . . . .		25
OPTIONAL UNITS, AND AUXILIARY UNITS, VS-616HII . . . . .	APPENDIX 4 . . . . .		48
Optional Units, VS-616HII . . . . .	APPENDIX 4 . . . . .	A4-1 . . . . .	48
<b>P</b> PARTS REPLACEMENT . . . . .	APPENDIX 6 . . . . .		51
Positioning . . . . .	3 . . . . .	3.2 . . . . .	10
Protective Circuit . . . . .	2 . . . . .	2.2.3 . . . . .	9
<b>R</b> Ratings and Specifications, VS-616HII . . . . .	APPENDIX 1 . . . . .		36
<b>RECEIVING.</b> . . . . .	1 . . . . .		5
<b>RENEWAL PARTS</b> . . . . .	APPENDIX 7 . . . . .		55
<b>S</b> Surge Absorber . . . . .	4 . . . . .	4.3 . . . . .	12
<b>T</b> TEST RUN . . . . .	5 . . . . .		15
Test Run, Presetting and Adjustment before . . . . .	5 . . . . .	5.2 . . . . .	15
Transistor Module . . . . .	APPENDIX 5 . . . . .	A5-2 . . . . .	50
Transistor Module, Replacement of . . . . .	APPENDIX 6 . . . . .	A6-4 . . . . .	53
Trial Operation/Test Run . . . . .	5 . . . . .	5.3 . . . . .	21
<b>TROUBLESHOOTING</b> . . . . .	9 . . . . .		28
Troubleshooting for Motor Symptom . . . . .	9 . . . . .	9.2 . . . . .	29
Troubleshooting for Failure Indications . . . . .	9 . . . . .	9.3 . . . . .	31
<b>V</b> VS OPERATOR MODEL JVOP-65-□ (OPTIONAL) (Fig. 18), USE OF . . . . .	5 . . . . .	5.3.3 . . . . .	24
<b>W</b> WIRE SIZE . . . . .	4 . . . . .	4.4 . . . . .	12
<b>WIRING</b> . . . . .	4 . . . . .		11
<b>WIRING INSTRUCTIONS</b> . . . . .	4 . . . . .	4.5 . . . . .	13

## INDEX OF FIGURES

<p>Fig. 1 VS-616HII Functional Block Diagram 6</p> <p>Fig. 2 Major Control Component Layout VS-616HII Model CIMR-H300B 7</p> <p>Fig. 3 Example of V/f Pattern 8</p> <p>Fig. 4 Accel/Decel Time Setting 8</p> <p>Fig. 5 VS-616HII Clearance Requirements for Proper Cooling and Maintenance 10</p> <p>Fig. 6 Example of VS-616HII Interconnections 11</p> <p>Fig. 7 Shielded Lead Termination 13</p> <p>Fig. 8 Grounding of Three VS-616HII Units 14</p> <p>Fig. 9 Connections for Megger Testing 14</p> <p>Fig. 10 Accel/Decel Time Set by Notch ① of 2S 18</p> <p>Fig. 11 ON/OFF Switches of 6S (1 to 8) 20</p> <p>Fig. 12 Master Frequency Reference Signal Selection 21</p> <p>Fig. 13 Auxiliary Frequency Reference Signal Selection 21</p> <p>Fig. 14 Voltage Selector 21</p> <p>Fig. 15 Radio Noise Reducing Filter Circuit Selector 21</p> <p>Fig. 16 Run and Stop Time Chart 21</p> <p>Fig. 17 Analog Operator (Optional) 22</p> <p>Fig. 18 Digital Operator (Optional) 23</p> <p>Fig. 19 VS Operator (Optional) 24</p> <p>Fig. 20 Points for Measurement 29</p>	<p>Fig. 21 Output Voltage Measurement 29</p> <p>Fig. 22 Model CIMR-H160B 38</p> <p>Fig. 23 With Analog Operator 39</p> <p>Fig. 24 With Digital Operator 39</p> <p>Fig. 25 With VS Operator 40</p> <p>Fig. 26 With User-Arranged Operation Circuit 41</p> <p>Fig. 27 With Magnetic Contactor for Start/Stop Operation (a) 42</p> <p>Fig. 28 With Magnetic Contactor for Start/Stop Operation (b) 43</p> <p>Fig. 29 With VS Operator and Analog Operator 44</p> <p>Fig. 30 With VS Operator and Digital Operator 45</p> <p>Fig. 31 With Braking Unit and Braking Resistor Unit 46</p> <p>Fig. 32 With Transistor (Open Collector) Used as Operation Command Signal 47</p> <p>Fig. 33 Control PC Board 51</p> <p>Fig. 34 Base Drive PC Board 51</p> <p>Fig. 35 Removing Diode Power Module and Diode 52</p> <p>Fig. 36 Removing Transistor Power Module and Transistor Module 53</p> <p>Fig. 37 Main Circuit Fuse 54</p> <p>Fig. 38 Cooling Fan Assembly 54</p>
---	---

## INDEX OF TABLES

<p>Table 1 VS-616HII Model Names and Ratings 5</p> <p>Table 2 Molded-Case Circuit Breakers and Magnetic Contactors 12</p> <p>Table 3 Surge Absorbers 12</p> <p>Table 4 Wire Size for Main and Control Circuits 12</p> <p>Table 5 Round Pressure Terminals 12</p> <p>Table 6 List of Setting Switches 16</p> <p>Table 7 V/f Pattern Selection 17</p> <p>Table 8 Accel/Decel Time Range Setting 18</p> <p>Table 9 Notch Selection of Electronic Thermal Overload Protective Switch (Use of Standard Motor) 19</p> <p>Table 10 Notch Selection of Electronic Thermal Overload Protective Switch (Use of VS-616HII Motor) 19</p> <p>Table 11 Inverter Capacity Selection 19</p> <p>Table 12 Selection of Operation Modes 20</p> <p>Table 13 Periodical Inspection 26</p> <p>Table 14 Failure Indication of Analog and Digital Operators 27</p> <p>Table 15 Failure Indication of VS-616HII 27</p>	<p>Table 16 Measuring Points and Instruments 28</p> <p>Table 17 VS-616HII Ratings and Specifications 36</p> <p>Table 18 Terminal Functions and Voltages of Main Circuit 37</p> <p>Table 19 Terminal Functions and Signals of Control Circuit 37</p> <p>Table 20 VS-616HII Optional Units 48</p> <p>Table 21 VS-616HII Auxiliary Units 49</p> <p>Table 22 Devices of VS Operator Model JVOP-65-□ 49</p> <p>Table 23 Diode Module Resistances 50</p> <p>Table 24 Transistor Module Resistances 50</p> <p>Table 25 Renewal Parts 55</p>
---	---

## DANGER

- Do not touch circuit components until "CHARGE" lamp is extinguished after turning off AC main circuit power supply. The capacitors are still charged and can be quite dangerous.
- Before changing switch settings (1S to 6S), turn off AC main circuit power and make sure that CHARGE lamp is off.
- Do not connect or disconnect wires and connectors while power is applied to the circuit.
- Do not check signals during operation.

## IMPORTANT

- Be sure to ground VS-616HII using the ground terminal Ⓔ. See par. 4.5.3 on page 14. Never connect main circuit output terminals Ⓚ(Ⓜ), Ⓛ(Ⓝ), Ⓜ(Ⓝ) to AC main circuit power.
- All the potentiometers of VS-616HII have been adjusted at the factory. Do not change their settings unnecessarily.
- Do not make withstand voltage test on any part of the VS-616HII unit, because it is electronic equipment using semi-conductors and vulnerable to high voltage.
- To make the insulation resistance test with a megger, special precautions must be taken. Before testing, refer to par. 4.5. on page 13.
- Control PC board employs CMOS IC's which are easily damaged by static electricity. Take care not to touch the CMOS elements inadvertently.

## 1. RECEIVING

This VS-616HII has been put through severe tests at the factory before shipped. After unpacking, however, check and see the following.

- Nameplate ratings meet your requirements. See Table 1.
- Leads and connectors are not disengaged.
- No damage while in transit.
- Bolts and screws are not loose.

If any part of VS-616HII is damaged or lost, immediately notify us giving full details and nameplate data.

Table 1 VS-616HII Model Names and Ratings

VS-616HII Model CIMR-	H220B	H300B
Max Motor Output kW (Hp)	220 (300)	300 (400)
Inverter Capacity kVA	300	400

## 2. VS-616HII FUNCTIONAL DESCRIPTION

### 2.1 VS-616HII FUNCTIONAL BLOCK DIAGRAM AND MAJOR CONTROL COMPONENT LAYOUT

VS-616HII functional block diagram is shown in Fig. 1 and major control component layout, in Fig. 2.

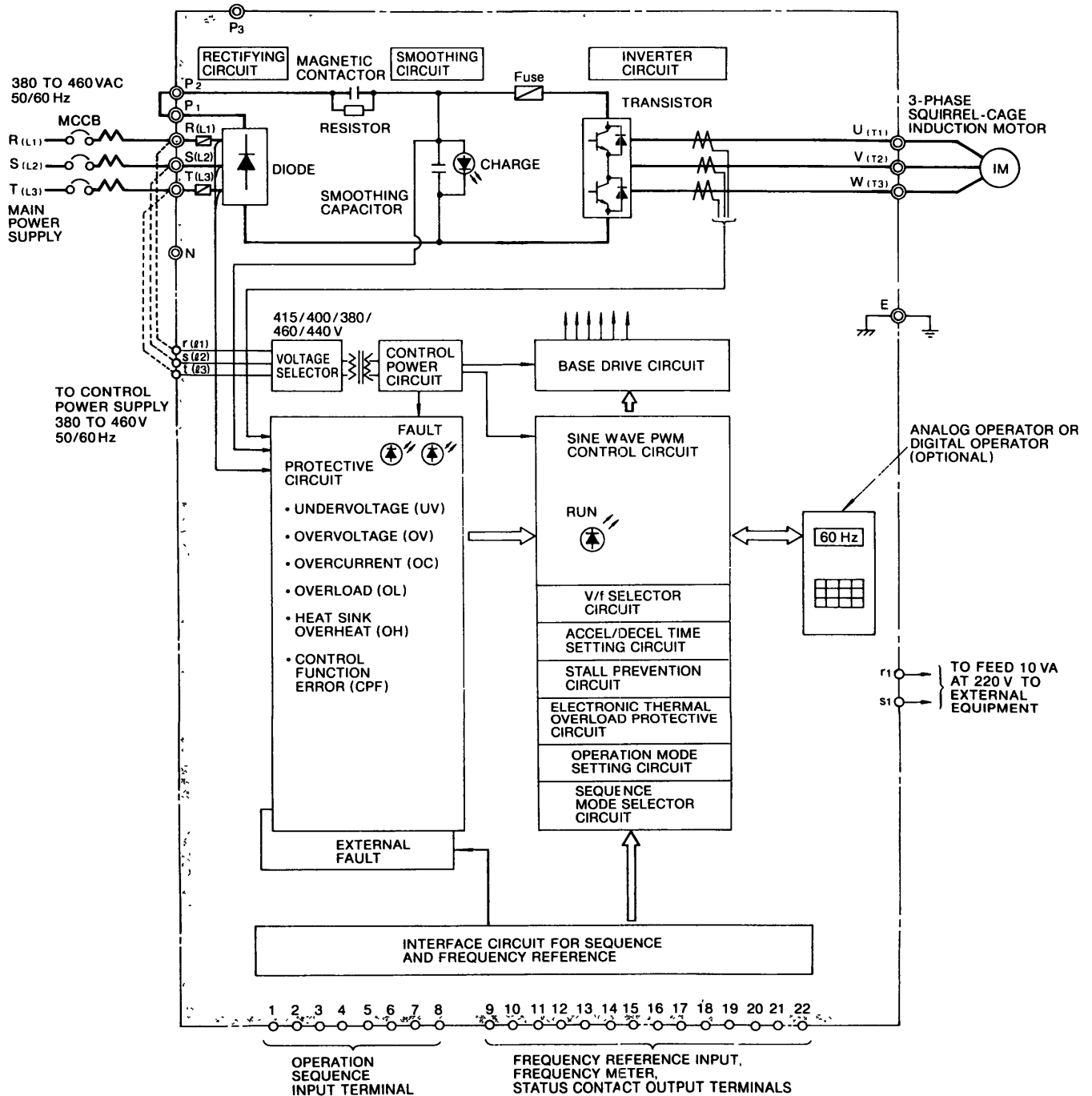
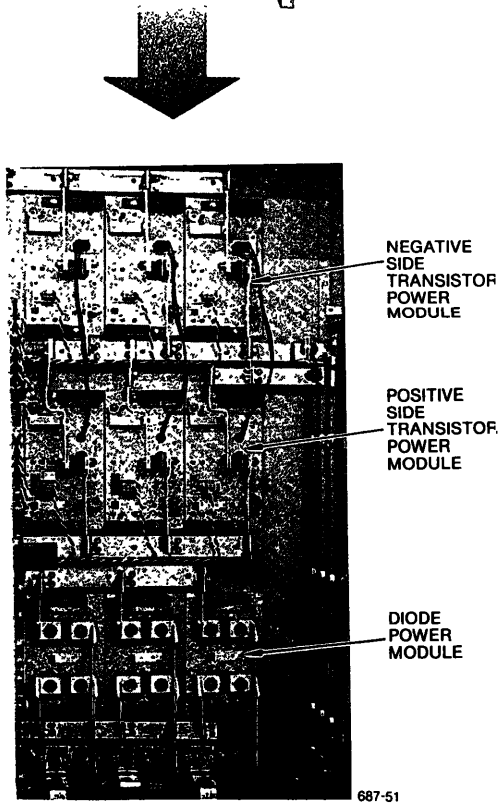
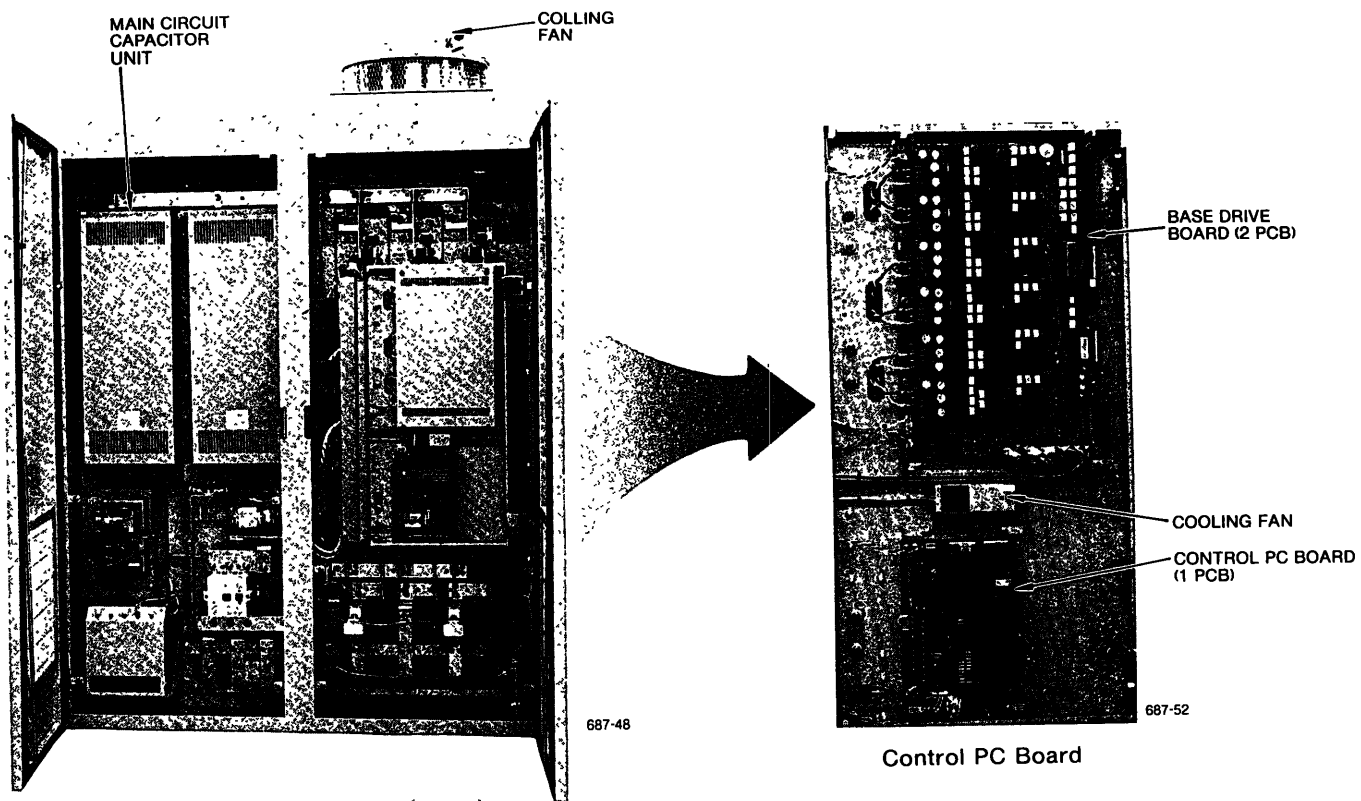

Fig. 1 VS-616HII Functional Block Diagram



Power PC Board  
(PC Board Plate Opened)

Fig. 2 Major Control Component Layout  
of VS-616HII Model CIMR-H300B

## 2.2 CIRCUIT OPERATIONAL DESCRIPTION

### 2.2.1 MAIN CIRCUIT

- (1) Rectifying circuit: Converts three-phase AC inputs through diodes to DC voltage.
- (2) Smoothing circuit: Smooths ripples in DC voltage by means of a capacitor.
- (3) Inverter circuit: Converts DC voltage to AC voltage of a preset frequency by switching six transistors. The output voltage level is controlled by changing the pulse width ratio, thus generating pseudo-sine waves.

### 2.2.2 CONTROL CIRCUIT

- (1) Base drive circuit: Drives the transistors in the inverter circuit.
- (2) Sine wave PWM control circuit: Calculates the pulse width every time a reference signal is received from the V/f control circuit, and outputs a PWM signal approximating a sine wave.
- (3) V/f selector circuit: Selects V/f pattern from 15 types of built-in voltage/frequency (V/f) patterns (Fig. 3).
- (4) Acceleration and deceleration time setting circuit: Smoothly changes the output frequency upon a rapid change of the frequency reference signal. Acceleration and deceleration times can be independently set by the acceleration (ACC) and deceleration (DEC) time setting potentiometers (Fig. 4).
- (5) Stall prevention circuit
  - During acceleration—Stops acceleration in the event of overcurrent condition and prevents the motor from stopping due to overcurrent. When the current returns to the rated value, acceleration is resumed.
  - During deceleration—Stops deceleration in the event of overvoltage condition and prevents the motor from stopping due to overvoltage. When the voltage returns to the rated value, deceleration is resumed.
  - In constant-speed operation—Reduces motor speed in the event of overload condition so as to prevent the motor from stopping due to overload. When overload condition is alleviated, Motor resumes running at normal speed.
- (6) Operation mode selector circuit: Selects one of eight operation modes individually to tailor the inverter to a specific application.
- (7) Sequence mode selector circuit: Selects the optimum function according to the application from ten modes.

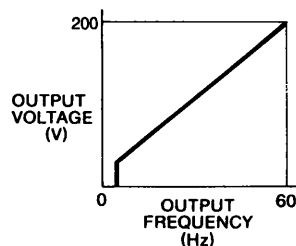

Fig. 3 Example of V/f Pattern

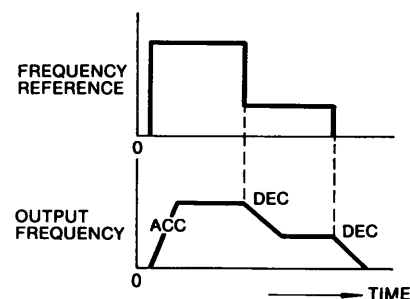

Fig. 4 Accel/Decel Time Setting



## 2.2.3 PROTECTIVE CIRCUITS

See Par. 8. Failure indication and Details on page 27 when protective circuits function.

(1) Undervoltage protective circuit: If the supply voltage drops below a set level or any one of phases is open, the undervoltage protective circuit shuts off the power transistors in the main circuit, and outputs a fault signal (UV operation). With the appropriate operation mode selected, operation can continue during power failure less than 2 seconds.

(2) Overvoltage protective circuit: If the main circuit DC voltage becomes higher than the set level, the overvoltage protective circuit shuts off the power transistors in the main circuit, and outputs a fault signal (OV operation).

(3) Overcurrent protective circuit: If more than 200% of the rated current flow is detected, the overcurrent protective circuit immediately shuts off the power transistors in the main circuit, and outputs a fault signal (OC operation).

(4) Overload protective circuit: When inverter or motor overload is detected by increased motor current, the overload protective circuit shuts off the power transistors in the main circuit after a specified time, and outputs a fault signal (OL operation).

(5) Electronic thermal overload protective circuit: Automatically adjusts protective characteristics to current and time to maximize operating capability.

## 3. INSTALLATION

### 3.1 LOCATION

Location of the equipment is important to achieve proper performance and normal operating life. The VS-616HI units should be installed in areas where the following conditions exist.

- Ambient temperature: -10 to +40°C (+14 to +104°F)
- Protected from rain or moisture.
- Protected from direct sunlight.
- Protected from corrosive gases or liquids.
- Free from airborne dust or metallic particles.
- Free from vibration.

### 3.2 POSITIONING

For cooling and maintenance purposes, make sure that there is sufficient clearance around the equipment, as shown in Fig. 5.

To keep effective cooling conditions, it must be installed vertically to the ground using the four mounting screws.

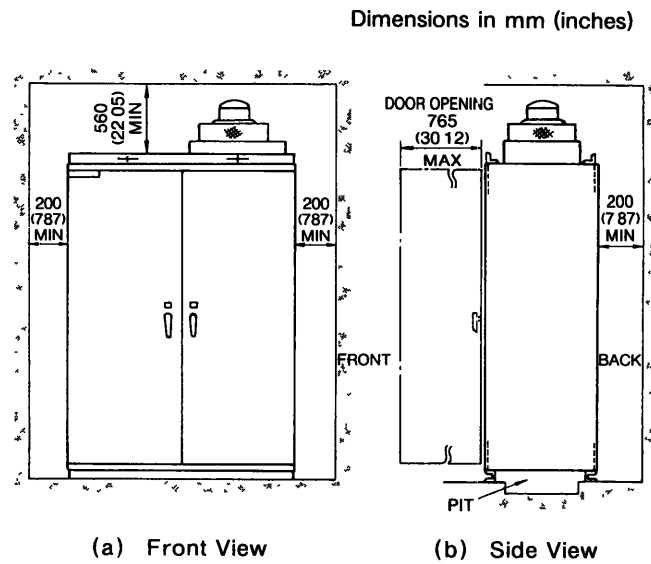

Note Figures shown above are for independently mounted inverter  
For installation in parallel with other cabinets, contact your Yaskawa  
representative

Fig. 5 VS-616HII Clearance Requirements  
for Proper Cooling and Maintenance

# 4. WIRING

## 4.1 INTERCONNECTIONS

Fig. 6 shows the connection diagram for combination of VS-616HII with VS operator. Remove the front cover before wiring. Connections should be made correctly, referring to Fig. 6.

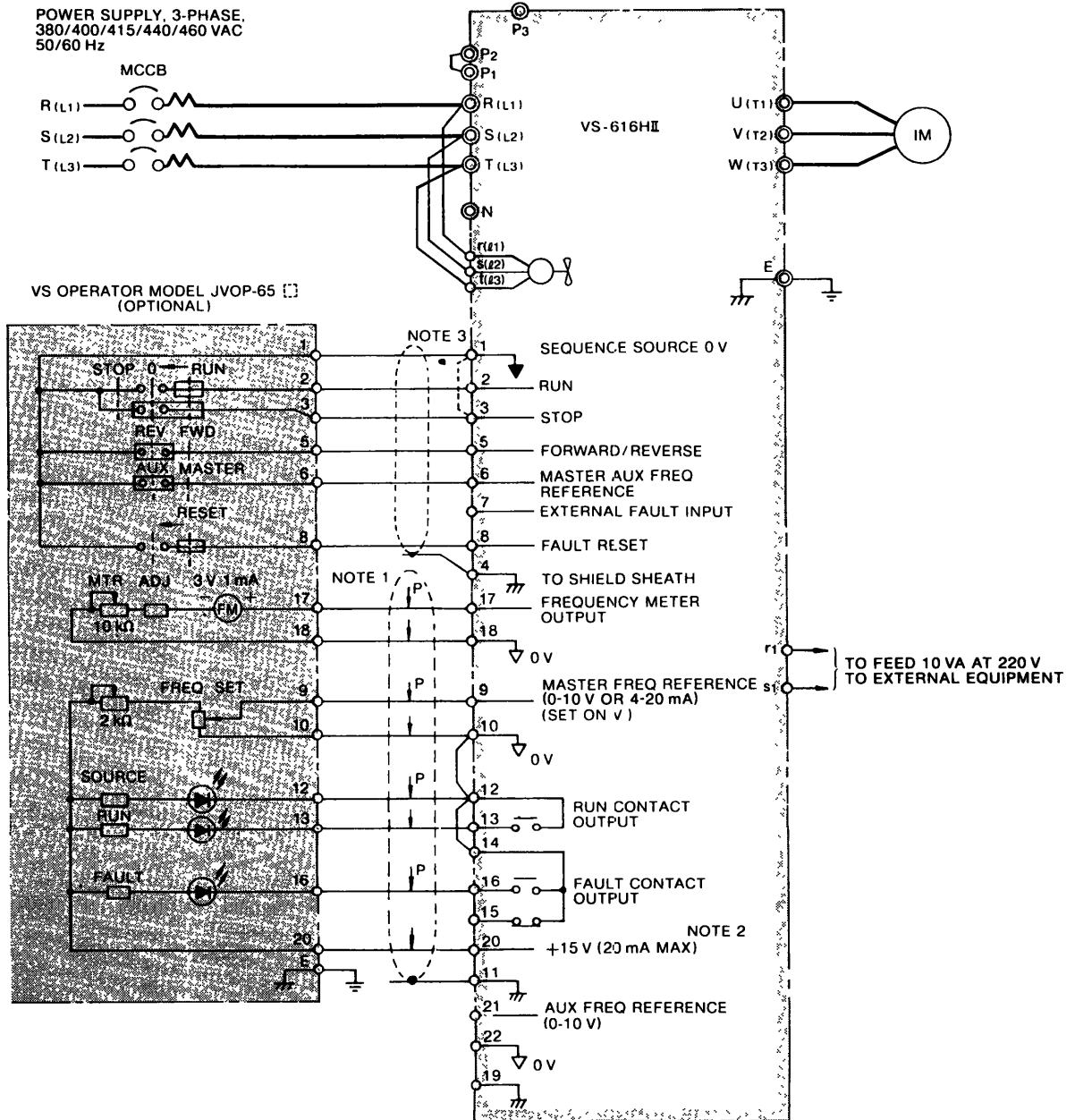

### Notes

- 1 indicates shielded leads and twisted-pair shielded leads
- 2 External terminal ② of +15 V has maximum output current capacity of 20 mA. It accommodates a single VS operator, if used
- 3 When VS operator is used, remove external terminal connections between ① and ③
- 4 External terminals P<sub>1</sub> and P<sub>2</sub> are short-circuited. To improve the power factor of power supply, remove the connections, and connect a reactor to P<sub>1</sub> and P<sub>2</sub>
- 5 Terminal symbol ③ shows main circuit, and ④, control circuit

### NOTE

Be sure to connect a surge absorber to the coils of relays, magnetic contactors, magnetic valves, or magnetic brakes.

Fig. 6 Example of VS-616HII Interconnections

## 4.2 MOLDED-CASE CIRCUIT BREAKER (MCCB) AND POWER SUPPLY MAGNETIC CONTACTOR (MC)

Be sure to connect MCCBs between power supply and VS-616HII input terminals Ⓡ (L1), Ⓢ (L2), Ⓣ (L3). Recommended MCCBs are listed in Table 2.

When a ground fault interrupter is used to prevent malfunction, setting current should be 200 mA or over and operating time, 0.2 sec or over.

Table 2 Molded-Case Circuit Breakers and Magnetic Contactors

VS-616HII	Model CIMR-		H220B	H300B
	Capacity	kVA	300	400
	Rated Output Current	A	450	600
Molded-Case Circuit Breaker (Model: NF-)	Rated Current*	A	800 (NF800†)	1000 (NF1000†)
Yaskawa Magnetic Contactors Type			HU-4893E	HU-593E

\* Comply with NEMA AB1

† Made by MITSUBISHI Electric

## 4.3 SURGE ABSORBER

For the surge absorbers to be connected to the coils of relays, magnetic contactors, magnetic valves, or magnetic relays, select types from the ones listed in Table 3.

Table 3 Surge Absorbers

Coils of Magnetic Contactor and Control Relay		Surge Absorber*		
		Type	Specifications	Code No
200 TO 230 V	Large-size	DCR2-50A22E	250 VAC 0.5 μF + 200 Ω	C002417
	Control Relay LY-2, -3 (OMRON) HH-22, -23 (Fuji) MM-2, -4 (OMRON)	DCR2-10A25C	250 VAC 0.1 μF + 100 Ω	C002482
	380 to 460 V	DCR2-50D100B	1000 VDC 0.5 μF + 220 Ω	C002630

\* Made by MARCON Electronics

## 4.4 WIRE SIZE

Wire sizes for main and control circuits are listed in Table 4, and Table 5 gives the selection of round pressure terminals according to wire size.

Table 4 Wire Size for Main and Control Circuits

Circuit	Terminals	VS-616HII Model CIMR-	Inverter Capacity kVA	Terminal Screw	Wire Size		Lead Type
					mm <sup>2</sup>	AWG	
Main	Ⓡ Ⓢ Ⓣ Ⓡ Ⓢ Ⓣ Ⓡ Ⓢ Ⓣ	H220B	300	M 12	325×2P	MCM650 ×2P	Power Cable 600 V vinyl-sheathed lead or equivalent
		H300B	400				
	Ⓡ	H220B to H300B	M 4	2-5.5	14-10		
Control	Ⓡ Ⓢ Ⓣ Ⓡ Ⓢ Ⓡ - Ⓢ	H220B to H300B		M 4	0.5-2	20-14	Twisted shielded lead* for instrumentation

\* Wire size should be determined considering voltage drop of leads Polyethylene-insulated vinyl-sheathed, with shielding

Table 5 Round Pressure Terminals

Wire Size		Terminal Screw	Round Pressure Terminal
mm <sup>2</sup>	AWG		
0.5	20	M4	R1.25-4
0.75	18		
1.25	16		
2	14	M4	R2-4
3.5	12	M4	R5.5-4
5.5	10		
325	MCM650	M12	RD325-12

## 4.5 WIRING INSTRUCTIONS

Complete VS-616HII interconnections, following the instructions given below. Be sure to check that connections are correct. Never use control circuit buzzer check.

### 4.5.1 Control Circuit

#### (1) SEPARATION OF CONTROL CIRCUIT LEADS AND MAIN CIRCUIT LEADS

Control circuit leads ① through ②② must be separated from main circuit leads ① (L1), ② (L2), ③ (L3), ④ (N), ⑤ (P1), ⑥ (P2), ⑦ (P3), ⑧ (T1), ⑨ (T2), and ⑩ (T3), to prevent erroneous operation caused by noise interference. If control circuit leads ⑪ to ⑫ (contact output) are connected to other power supply, separate them from ① to ⑩ and ⑬ to ⑭.

#### (2) CONTROL CIRCUIT

Use the twisted shielded lead or twisted-pair shielded lead for the control circuit line and connect the shield sheath to the any of the inverter terminals ④, ⑩, or ⑬. See Fig. 7.

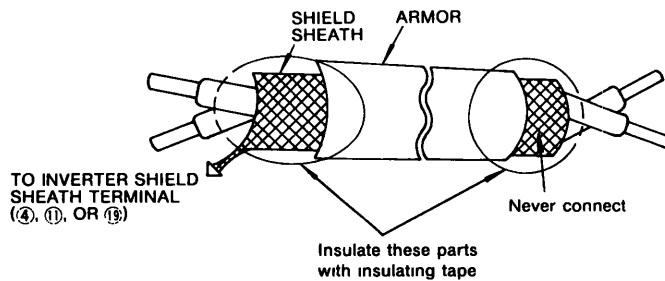

Fig 7 Shielded Lead Termination

#### (3) WIRING DISTANCE

It is recommended that the wiring distance of the signal leads (①-②②) be 50 meters (164 feet) or below.

### 4.5.2 Main Circuit

#### (1) DIRECTION OF PHASE ROTATION OF POWER

- Phase rotation of power must be forward. Check that the air is exhausted from the fan.
- When inverter output terminals ⑧ (T1), ⑨ (T2), and ⑩ (T3) are connected to motor terminals ⑧ (T1), ⑨ (T2), and ⑩ (T3), the motor rotates counterclockwise, viewed from opposite drive end, upon forward operation command. To reverse the rotation, interchange any two of motor leads.

(2) Never connect power supply to output terminals ⑧ (T1), ⑨ (T2), or ⑩ (T3).

(3) Care should be taken to prevent contact of wiring leads with VS-616HII cabinet. Short-circuit may result.

(4) To feed DC power supply from terminals ⑤ (P2) and ④ (N), remove the leads across ① (L1) and ② (L1), ③ (L2) and ④ (L2), ⑤ (L3) and ⑥ (L3). Connect control circuit power supply (380/460 V, 50/60 Hz) across terminals ② (L1), ③ (L2), ④ (L3).

(5) Never connect power factor correction capacitor, or noise filter to VS-616HII output.

### 4.5.3 Grounding

Make a positive grounding using ground terminal Ⓔ on the casing of VS-616HII.

- (1) Ground resistance should be 100Ω or less.
- (2) Never ground VS-616HII in common with welding machines, motors, and other large-current electrical equipment, or ground pole. Run the ground lead in a separate conduit from leads for large-current electrical equipment.
- (3) Use ground lead listed in Table 4 and make the length as short as possible.
- (4) Even when VS-616HII is grounded through its mountings such as channel base or steel plate, be sure to ground VS-616HII using the ground terminal Ⓔ.
- (5) Where several VS-616HII units are used side by side, all the units should preferably be grounded directly to the ground poles. However, connecting all the ground terminals of VS-616HII in parallel, and ground only one of VS-616HII to the ground pole is also permissible (Fig. 8). However, do not form a loop with the ground leads.

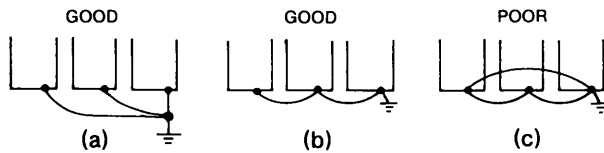

Fig 8 Grounding of Three VS-616HII Units

### INSULATION RESISTANCE TEST

For megger-testing the main circuit, measure the insulation resistance with a 500 V megger.

Connect the AC input, output terminals Ⓘ (Ⓘ1), Ⓢ (Ⓘ2), Ⓔ (ⒾL1), Ⓢ (ⒾL2), Ⓣ (ⒾL3), Ⓝ, Ⓟ1, Ⓟ2, Ⓟ3, Ⓡ (ⒾT1), Ⓡ (ⒾT2), and Ⓡ (ⒾT3) by a common wire, and connect the control terminals ①-②② (④, ⑪ and ⑱ excluded) by a common wire, as shown in Fig. 9. After that, measure the insulation resistance between the common wire of input/output terminals and ground with a megger. Never measure the insulation resistance of circuit other than the main circuit (power line). For both the input and output terminals, a reading above 1MΩ is considered satisfactory.

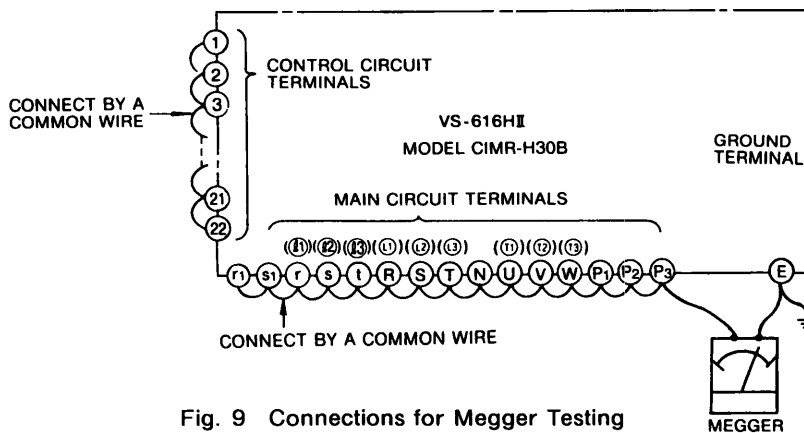

Fig. 9 Connections for Megger Testing

## **5. TEST RUN**

### **5.1 CHECKS BEFORE TEST RUN**

After completing mounting and connection of units, check for:

- Correct connections
- No short-circuit conditions
- No loose screw terminals (Check especially for loose wire clippings.)
- Proper load condition

### **5.2 PRESETTING AND ADJUSTMENT BEFORE TEST RUN**

Before setting, be sure to shut off the AC main circuit power and make sure that the CHARGE lamp goes out. If any setting except for accel/decel time is performed with the power on, the following failure indicators will blink:











- FAULT lamp on the inverter
- CPF lamp, if the Analog or Digital operator is used

If any setting is changed during operation, the operation will continue with the setting made before the change. If the VS-616HI is turned off and then on again, it operates with the changed settings.

- The VS operator provides no failure indication for setting with power ON.

## 5. 2 PRESETTING AND ADJUSTMENT BEFORE TEST RUN (Cont'd)

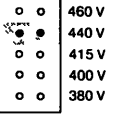
Table 6 List of Setting Switches

Switch Name		Symbol	Function	Factory-setting	
Control PC Board (1 PCB)	V/f Pattern Selector Switch		Selects one of 15 V/f patterns to match specific applications.	Notch ①	
	Accel/Decel Time Setting	Switch		Selects accel/decel time range (0.1 to 1800 seconds).	Notch ①
		Potentiometer		Accel/decel times independently adjustable between the time range selected by 2S.	Scale 5
	Sequence Mode Selector		Selects one of 15 types of sequences according to application requirements.  <b>CAUTION</b> Do not tamper with this switch. Any changes or adjustments must be made by the factory.	Notch ②	
	Electronic Thermal Overload Protective Switch		Protects motor and inverter from over-current conditions if motor capacity is different from inverter capacity.	(See Tables 8 and 9.)	
	Inverter Capacity Selector Switch		Set according to inverter capacity.  <b>CAUTION</b> Same as for 3S.	(See Table 10.)	
	Operation Mode Selector Switch		Selects the operation mode according to specific applications.	OFF	
	Master Frequency Reference Signal Selector		Selects either a current signal (4-20mA) or a voltage signal (0-10V) to feed frequency reference signal at terminal ⑨.	V (Voltage signal)	
	Auxiliary Frequency Reference Signal Selector		Set to input frequency reference at external terminal ⑩. When the Analog operator is used for frequency setting, set the shunt on "L" because signals from external terminal ⑩ are not accepted.	R	
Voltage Selecting PC Board (3 PCB)	Voltage Selector		Selects voltage according to supply voltage.	440	
	Radio Noise Reducing Filter Circuit Selector		Selects radio noise reducing filter circuit according to application. A: Ground interruptor not used. B: Ground interruptor used. Shuts off ground circuit and prevents malfunction if the interruptor trips.	A	



(1) Setting of V/f pattern selector switch (1S)

The V/f pattern selector switch (1S) has been factory-set at the notch ① for most applications. For specific applications such as fans and pumps, high-starting troques, or machine tools, select the optimum V/f pattern for motor running, according to the load characteristics. (See Table 7.)

Table 7 V/f Pattern Selection (Input Supply Voltage: 400 V)

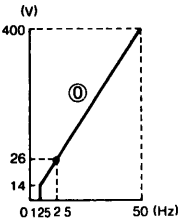
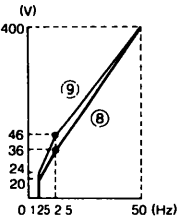
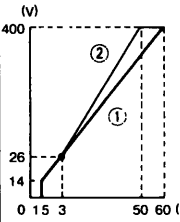
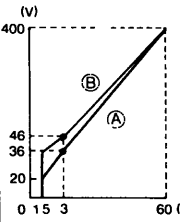
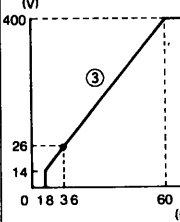
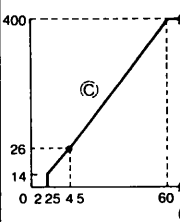
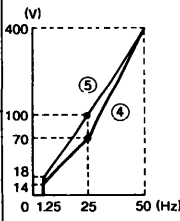
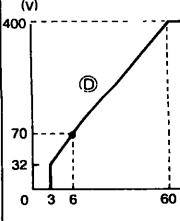
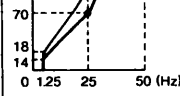
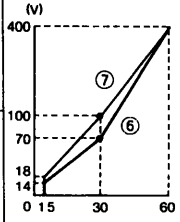
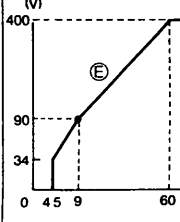
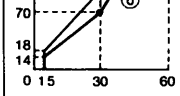
Applica-tion	Specification	1S Notch	V/f Pattern	Applica-tion	Specification	1S Notch	V/f Pattern		
General Purpose	50Hz	①		High Starting Torque	50Hz	Starting Torque Low	⑧		
									Starting Torque High
	60Hz	60Hz Saturation	①		High Starting Torque	60Hz	Starting Torque Low	①	
		50Hz Saturation	②				Starting Torque High	②	
		72Hz	③			90Hz	③		
	Variable Output Operation (Fans and Pumps)	50Hz	Variable Torque 2		Constant Output Operation (Machine Tools)	120Hz	④		
Variable Torque 1			⑤						
60Hz		Variable Torque 2	⑥			180Hz	⑤		
		Variable Torque 1	⑦						

Note

- 1 Take account of the following conditions and others when selecting V/f pattern
    - Pattern matching the voltage-frequency characteristic of the motor
    - According to the maximum motor speed
  - 2 V/f pattern for high starting torque should be selected for
    - Long wiring distance
    - Large voltage drop at start
    - AC reactor connected to input or output of the inverter
    - Use of motor of the rating below the max
- For details, contact Yaskawa representative

## 5. 2 PRESETTING AND ADJUSTMENT BEFORE TEST RUN (Cont'd)

### (2) Setting of acceleration and deceleration times (2S, ACC, DEC)

Set the acceleration and deceleration times using acceleration time range selector switch (2S), and the acceleration (ACC) and deceleration (DEC) time setting potentiometers (Table 8).

2S has been factory-set to notch ①, and the ACC and DEC potentiometers have been individually set to scale 5 (approximately 10 seconds).

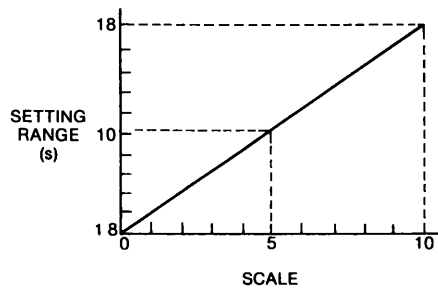

Fig. 10 Accel/Decel Time Set by Notch ① of 2S

Table 8 Accel/Decel Time Range Setting

2S Notch	Accel/Decel Time Setting Range (sec)
①	0.1-6
① (Factory setting)	1.8-18
②	6-60
③	18-180
④	60-600
⑤ - ⑩	180-1800
Ⓔ	Function of soft start/stop not provided.
Ⓕ	For calibrating freq meter. See par 5.4. on page 25

### (3) Selection of sequence mode (3S)

The standard sequence mode selector switch (3S) is paint-locked to notch ①.

Notches ① to ⑯ provide sequences for special applications. For details, contact Yaskawa representative.

### (4) Setting of electronic thermal setting switch (4S)

When a motor has a capacity different from the maximum applicable capacity of the inverter, the VS-616HII setting must be changed to suit the motor capacity to protect the motor positively. Table 9 on page 19 shows the selections of Yaskawa standard motors (4 poles). The switch has been factory-set to the notch marked off by shading.

When VS-616HII motors are used, set the switch (4S) according to Table 10 on page 19. Notch F inactivates the motor protection by the electronic thermal function.

**Table 9 Notch Selection  
of Electronic Thermal Overload Protective Switch  
(Use of Standard Motor)**

VS-616HII Model CIMR-	kVA	Max Motor Output kW (Hp)	
		220 (300)	300 (400)
H220B	300	⑥	—
H300B	400	③	⑤

 Shaded areas show factory-set notches

**Table 10 Notch Selection  
of Electronic Thermal Overload Protective Switch  
(Use of VS-616HII Motor)**

VS-616HII Model CIMR-	kVA	Max Motor Output kW (Hp)	
		220 (300)	300 (400)
H220B	300	⑨	—
H300B	400	Ⓒ	⑨

(5) Selection of inverter capacity (5S)

The switch 5S has been factory-set to agree with the inverter capacity as shown in Table 11.

**Table 11 Inverter Capacity Selection**

VS-616HII Model CIMR-	kVA	5S Notch
H220B	300	Ⓕ
H300B	400	

(6) Selection of operation modes (6S)

Select the operation modes from Table 12 according to the application, and set switch (6S) as appropriate.

Notches ① to ⑦ have been factory-set to OFF () and ⑧ to ON.

## 5.2 PRESETTING AND ADJUSTMENT BEFORE TEST RUN (Cont'd)

Table 12 Selection of Operation Modes

6S Notch	Function	ON/OFF Setting	Description of Operation Mode
①	Dynamic Braking (DB)	OFF	The motor is decelerated until it reaches 1/40 rated speed with the frequency reduced, and DB operation is performed at the speeds less than 1/40 rating.
		ON	The motor is decelerated until it reaches 1/40 rated speed with the frequency reduced, and is coasting to a stop.
②	Stopping	OFF	The motor stops in the mode set by notch ① of 6S when a STOP command is input.
		ON	The motor is coasting to a stop when a STOP command is input ignoring 6S setting of notch ①.
③	Stall Prevention during Deceleration	OFF	Too high load GD <sup>2</sup> during deceleration activates stall prevention function and extends the set decel time.
		ON	Stall prevention function during deceleration not provided.
④	Stopping Free-run Motor	OFF	DB operation is not applied at the start.
		ON	Motor starts after DB operation is applied. (DB operation within 1/5 decel time)
⑤	Operation Continuation at Momentary Power Failure	OFF	Motor is coasting to a stop at momentary power failure.
		ON	Motor resumes running after approximately 2 seconds or less of a momentary power failure, it coasts to a stop after more than 2 seconds of a momentary power failure.
⑥	Operation Continuation after Momentary Power Failure* (When notch ⑤ of 6S is ON)	OFF	Restarts operation after motor residual voltage is reduced upon recovery from momentary power failure.
		ON	Immediately restarts operation upon recovery from momentary power failure.†
⑦	Jogging	OFF	Frequency acceleration and deceleration is performed at 1/10 rated speed when jog command is input.
		ON	
⑧	Supply Voltage	OFF	200 to 230 V
		ON	380 to 460 V

\*Speed search function starts when motor speed is decreased due to momentary power failure and load current

†OC (overvoltage) protective circuit may be activated according to power recovery timing and load conditions. AC reactor should be connected or an inverter one size larger than specified should be selected

Fig. 11 ON/OFF Switches of 6S (1 to 8)

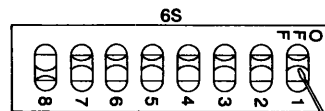

When changing settings, switches must be treated delicately

MINI-SCREWDRIVER

(7) Selection of master frequency reference signal

When the frequency reference signal is input from input terminal ⑨, select either a current signal (4 to 20 mA) or a voltage signal (0 to 10 V) (Fig. 12). The voltage reference signal (V) is factory-selected.

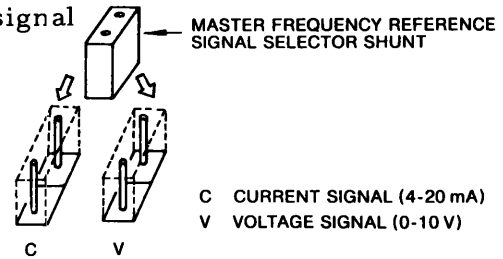

Fig. 12 Master Frequency Reference Signal Selection

(8) Selection of auxiliary frequency reference signal

When the Analog operator (optional) is not used, input terminal ⑫ can be used for frequency setting. The auxiliary frequency reference signal selector shunt must be set as illustrated in Fig. 13.

The shunt is factory-set to (L) for use with Analog operator, and to (R) for other applications.

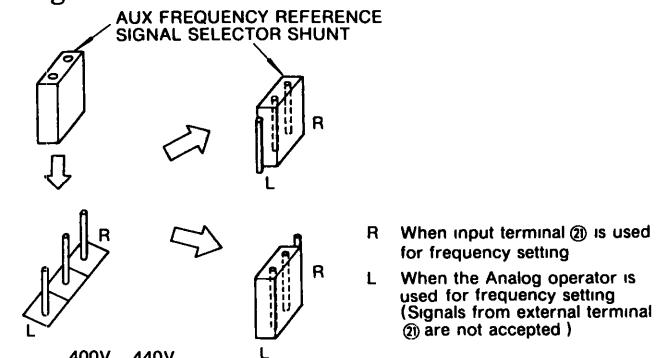

Fig. 13 Auxiliary Frequency Reference Signal Selection

(9) Selection of supply voltage

Connect the shunt in Fig. 14 according to the supply voltage. The shunt is factory-set to 440 V.

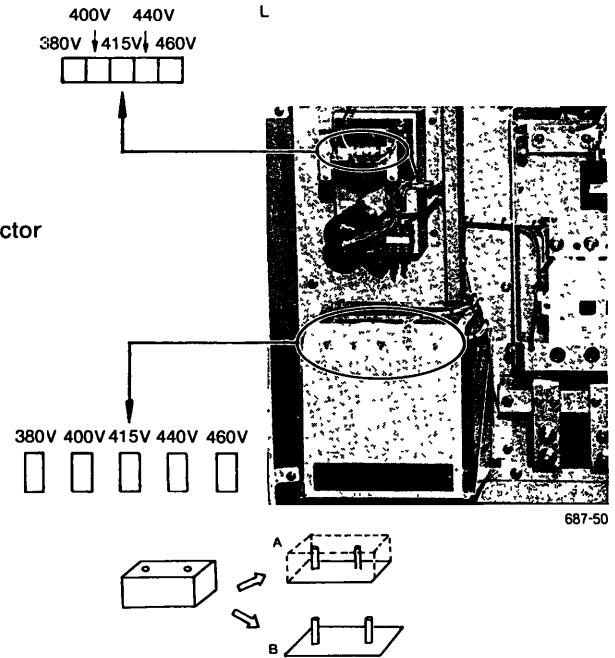

Fig. 14 Voltage Selector

(10) Selection of radio noise reducing filter circuit

The radio noise reducing filter prevents radio noise generated in the inverter unit from interfering with the AC main circuit.

The selector shunt has been preset on (A) at the factory. When used with ground fault interrupter, it may trip due to radio noise. To prevent this, change the shunt to (B). This shuts off ground circuit if the interrupter trips and prevents resultant erroneous operation.

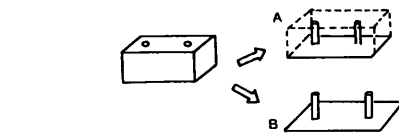

Fig. 15 Radio Noise Reducing Filter Circuit Selector

### 5.3 TRIAL OPERATION/TEST RUN

Whenever possible, uncouple the motor from the driven machine. If the motor must be rotated with the driven machine connected, make sure that all dangerous conditions have been eliminated.

Fig. 16 shows the run-stop time chart when notches ① and ② of operation mode setting switch 6S are set to OFF.

Test run procedure is given in three ways (use of Analog operator, Digital operator, and VS operator). If any fault occurs, isolate the trouble spot, referring to par. 9 Troubleshooting.

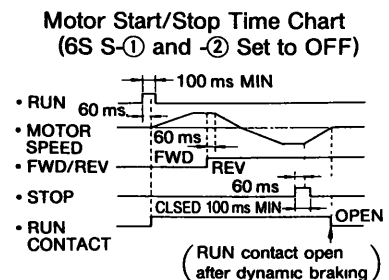

Fig. 16 Run and Stop Time Chart

### 5.3.1 Use of Analog Operator Model JVOP-72 (Optional)

1. Set the AUTO/MAN switch to MAN, move the FWD/REV switch to FWD, and turn the FREQ SET potentiometer fully counterclockwise to LOW.
2. Turn on the VS-616HI AC main circuit power (circuit breaker). The STOP lamp (orange) lights.
3. Move the RUN/STOP switch to RUN with the FREQ SET potentiometer at LOW. It causes the RUN lamp (green) to light.
4. Slowly turning the FREQ SET potentiometer clockwise starts running the motor, with the frequency meter reading the output frequency. Make sure that the motor is running forward. If shaft rotation is incorrect, turn off AC main circuit power, and reverse any two of motor leads ① (T1), ② (T2), ③ (T3).
5. By turning the FREQ SET potentiometer slowly clockwise or counterclockwise, the motor accelerates or decelerates smoothly. Set the maximum motor speed by turning the FREQ SET potentiometer fully clockwise to HIGH and check the motor for normal running. After this check, return the FREQ SET potentiometer fully counterclockwise to LOW.
6. To stop the motor, set the RUN/STOP switch to STOP, and the STOP lamp comes on.

#### Preset Start

To make the preset start (a "one-touch" operation at a preset frequency), use steps 1 to 2 mentioned above and then proceed as follows.

(a) Set the frequency using frequency setting potentiometer. Move the RUN/STOP switch to RUN, and the motor accelerates within the time set in par. 5.2 (2) on page 18, then keeps on running at the preset frequency. If the motor does not run smoothly during acceleration (with the acceleration stall prevention function working), or if any FAULT lamp comes on, the acceleration time is assumed to have been set too short for the load level; extend the acceleration time.

(b) Set the RUN/STOP switch to STOP to stop the motor. The motor decelerates in the time set in par. 5.2 (2) on page 18, then stops.

If the motor does not run smoothly during deceleration function working), or if any failure indicator comes on, the deceleration time is assumed to have been set too short for the load level; increase the deceleration time.

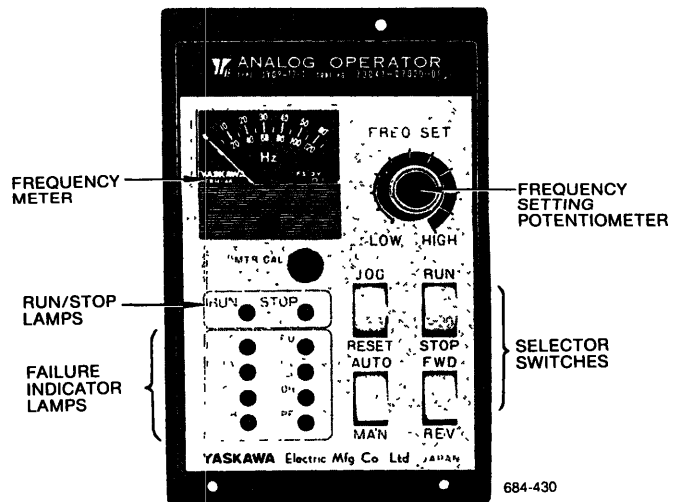

Fig. 17 Analog Operator (Optional)

### 5.3.2 Use of Digital Operator Model JVOP-71 (Optional) (Fig. 18)

1. Turn on the VS-616HII AC main circuit power (circuit breaker). Then "AUTO," "MONI," "0.0 Hz," "STOP," and "FWD" are shown on the digital operator display.
2. Display "MAN" by pressing 

AUTO
MAN

 key.
3. Make sure that "FWD" is displayed.  
If "REV" is displayed, press 

FWD
REV

 key to display "FWD."
4. Confirm that the motor runs forward slowly while 

JOG
-----

 key is being pressed. If shaft rotation is incorrect, turn off AC main circuit power, and reverse any two of motor leads. (The jog operation mode outlined in para. 5.2 (6) on page 20 is selected.)
5. Display "REV" by pressing 

FWD
REV

 key again, and make sure that the motor runs in reverse direction with JOG key pressed.
6. Pressing 

DISP
------

 key changes "MONI" to "SET," placing the operator in the setting mode. Select a digit to be set by operating 

◀
---

 or 

▶
---

 key. It is indicated by blinking. Pressing 

◀
---

 key moves blinking one space to the left, and 

▶
---

 key one space to the right. Set the required frequency by operating 

▲
---

 or 

▼
---

. Pressing 

▲
---

 key increases the blinking value by one, and 

▼
---

 key decreases by one. After finishing the setting, press 

ENTER
-------

 key.
7. Pressing 

RUN
-----

 key displays "RUN." The motor then accelerates within the preset acceleration time and keeps on running at the frequency set in step 6.
8. To display the output frequency, press 

DISP
------

 key again. "SET" changes to "MONI," and the output frequency appears.
9. Pressing 

STOP
------

 key switches "RUN" to "STOP." The motor then decelerates within the preset deceleration time and stops.

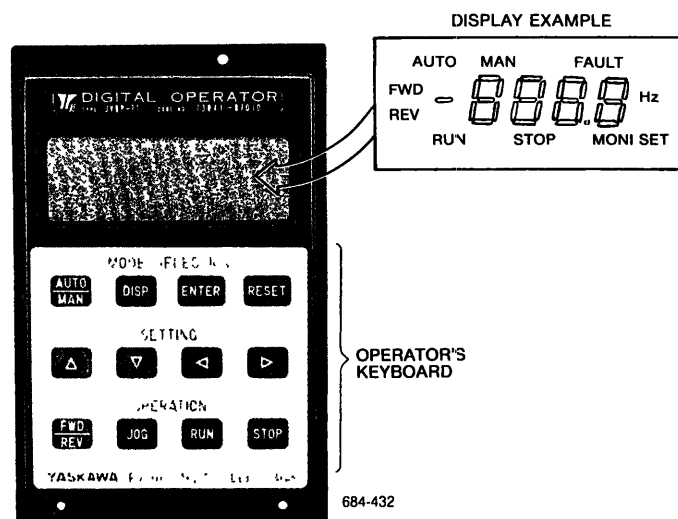

Fig. 18 Digital Operator (Optional)

### 5.3.3 Use of VS Operator Model JVOP-65 (Optional) (Fig. 19)

Complete the connection of units according to example in Fig. 6, on page 11 and perform the test run using the following procedures.

1. Set the MASTER/AUX switch to MASTER, move the FWD/REV switch to FWD, and turn the FREQ SET potentiometer fully counterclockwise to LOW.
2. Turn on the VS-616HI AC main circuit power (circuit breaker), and the SOURCE lamp (green) will light.
3. Change the RUN/STOP switch to RUN with the FREQ SET potentiometer at LOW, and RUN lamp (green) will light.
4. Slowly turning the FREQ SET potentiometer clockwise causes the motor to start running and the frequency meter to indicate the output frequency. Make sure that the motor is running forward. If shaft rotation is incorrect, turn off AC main circuit power, and reverse any two of motor leads  $\text{U}(\text{T1})$ ,  $\text{V}(\text{T2})$ ,  $\text{W}(\text{T3})$ .
5. By turning the FREQ SET potentiometer clockwise or counterclockwise, the motor accelerates or decelerates smoothly. Also, set the maximum speed of the motor by turning the FREQ SET potentiometer fully clockwise to HIGH, and check the motor for normal running. After this check, return the FREQ SET potentiometer fully counterclockwise to LOW.
6. To stop the motor, set the RUN/STOP switch to STOP, and the RUN lamp goes out after the motor stops.

#### Preset Start

To make the preset start (a "one-touch" operation at a preset frequency), apply steps 1 to 2 mentioned above and then proceed as follows.

(a) Set the frequency using frequency setting potentiometer. Set the RUN/STOP switch to RUN, and the motor accelerates within the time set in par. 5.2 (2) on page 18, then keeps on running at the preset frequency. If the motor does not run smoothly during acceleration (with the acceleration stall prevention function working), or if a FAULT lamp comes on, the acceleration time is assumed to have been set too short for the load level; increase the acceleration time.

(b) To stop the motor, change the RUN/STOP switch to STOP. The motor decelerates within time set in par. 5.2 (2) on page 18, then stops. If the motor does not run smoothly during deceleration (with the deceleration stall prevention function working), or if a FAULT lamp comes on, the deceleration time is assumed to have been set too short for the load level; increase the deceleration time.

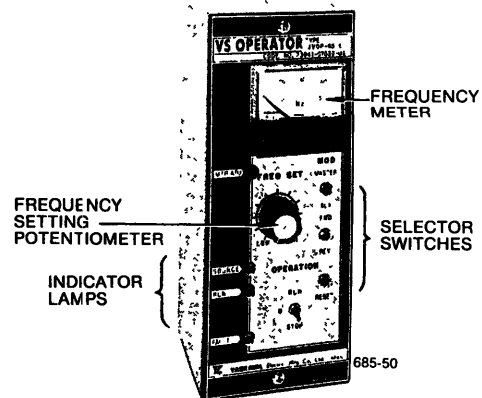

Fig. 19 VS Operator (Optional)



## 5.4 FREQUENCY METER CALIBRATION

When the Analog or VS operator is used, the frequency meter must be calibrated. The motor need not be run during calibration. Perform the following procedures:

1. Shut off the AC main circuit power.
2. Record the position (notch number) of setting switch 2S on the control PC board.
3. Set 2S to notch ⑩ .
4. Turning on the control circuit input power supply (Ⓘ, Ⓢ or Ⓛ<sub>1</sub>, Ⓛ<sub>2</sub>) causes the meter to indicate approximately the rated frequency.
5. Adjust MTR CAL potentiometer of the Analog operator (or MTR ADJ potentiometer of the VS operator) so that the meter reads the rated frequency.
6. After the adjustment, turn off AC main circuit power again, then return setting switch 2S to the recorded position.

## 6. OPERATION AT LOAD

After the no-load operation, turn off the AC main circuit power, and connect the driven machine to the motor. Make sure that the driven machine is in running condition, and there is no danger around VS-616HII system, and run the motor under load in exactly the same way as for test run.

### PRECAUTION

- (1) Start the motor after making sure that the motor is stopped. If the operation is started during motor coasting, overvoltage (OV) or overcurrent (OC) protective circuit may be operated.
- (2) The motor can be operated by an operation signal from either the inverter-mounted operator or external terminal ② . This selection can be made only when the inverter is standby.
- (3) The motor can be stopped unconditionally by a STOP signal from either the inverter-mounted operator or external terminal ③ . Either stop command takes priority over any other command in operation.
- (4) When a standard motor is driven with the inverter, there is a little increase in motor temperature, noise, and vibration as compared to the operation from the commercial power supply.
- (5) The motor cooling effect lowers during low-speed running. The torque needs to be reduced in accordance with the frequency. (For the reduction ratio, refer to the catalog or technical sheet.)
- (6) Even with small load, never use a motor whose current exceeds the inverter rating. When two or more motors are operated, check to be sure that the total motor current is not larger than inverter rating.
- (7) When starting and stopping the motor, be sure to use the operation signals (RUN and STOP), not the magnetic contactor on AC main circuit power side. Exception: If the magnetic contactor is to be used to start and stop a motor, see A3-2, (5) on page 42. Care should be taken not to start and stop the motor frequently.

## 7. MAINTENANCE

VS-616HII requires almost no routine checks. It will function efficiently and longer if it is kept clean, cool and dry, observing precautions listed in 3.1 Location, on page 9. Especially check for tightness of electrical connections, discoloration or other signs of overheating. Use Table 13 as the inspection guide. Before servicing inspection, turn off AC main circuit power and be sure that CHARGE lamp is off.

Table 13 Periodical Inspection

Points to be Checked		Corrective Action	Remarks
Cooling Fan	<ul style="list-style-type: none"> <li>• Undue noise</li> <li>• Abnormal vibration</li> </ul>	<ul style="list-style-type: none"> <li>• Check for foreign matter and remove if any</li> </ul>	Guide for replacement intervals <ul style="list-style-type: none"> <li>• For rated currents from 200 to 900 A Every 30,000 hours</li> <li>• For rated currents 1500 A and 1650 A Replacement of motor bearings every 20,000 hours</li> </ul>
Air Filter	<ul style="list-style-type: none"> <li>• Dust clogging</li> </ul>	<ul style="list-style-type: none"> <li>• If half of effective area is choked with dust, wash in a solution of detergent</li> </ul>	<ul style="list-style-type: none"> <li>• Washing every 3 to 6 months (depending upon operating conditions)</li> <li>• Replace with new filter, when washed about ten times</li> </ul>
Others	<ul style="list-style-type: none"> <li>• Dirts and dust accumulated</li> <li>• Hand tools left in the equipment</li> <li>• Bolts or nuts not loosened</li> </ul>	<ul style="list-style-type: none"> <li>• Clean by means of suction type device</li> </ul>	<ul style="list-style-type: none"> <li>• Dust and dirts on thyristors and cooling fins deteriorate heat dissipation, and increase insulation resistance.</li> <li>• Special locking means are provided for nuts to fix thyristors and busbars</li> </ul>

## 8. FAILURE INDICATION AND DETAILS

A failure, if it is detected, can shut off the output power transistor and output FAULT contact signals across control circuit terminals (14), (15), and (16).

When Analog or Digital operator is used, failure indications listed in Table 13 will function. When neither of them is used, failure conditions are shown by FAULT lamp on the VS-616HI.

Table 14 Failure Indication

Indication	Symptom	VS-616HII Operation
FU (Fuse Blown)	Main circuit fuse blown.	Inverter stops output momentarily (Motor is coasting )
OC (Overcurrent)	More than 200 percent of rated current flow in inverter output side. (Instantaneous operation)	
OL (Overload)	Overload of motor and inverter detected by electronic thermal.	
OV or OU ** (Overvoltage)	Main circuit DC voltage higher than approx 790 V.	
UV* or UU** * (Undervoltage)	Main circuit DC voltage lower than approx 420 V.	
OH (Heat Sink Overheat)	Thermoswitch operated by overheat of heat sink of main circuit semiconductor.	
EB or Eb * (External Failure)	Fault signal is input from external terminal ⑦.	#
CPF	Steady (Major Control Function Error)	
	Blinks (Setting error)	Any one of setting switches (1 S to 6 S) changed with power ON.

\* In operation continuation after a momentary power failure mode (⑤ notch of 6S ON), UV lamp is flashing for approx two seconds

\* For Digital operator display

\* FAULT will be displayed with OU on the screen of Digital operator

\*\* Inverter continues operation When the setting is returned to the state before change, the display replaces the normal operation status

Table 15 Failure Indication of VS-616HII

Indication		Cause	VS-616HII Operation
F1	F2		
□	■ ■ ■	FU (Fuse Blown): Main circuit fuse blown.	Inverter stops output momentarily. (Motor is coasting )
□	■ ■ ■	OC (Overcurrent): More than 200 percent of rated current flow in inverter output side.	
□	■ ■ ■	OL (Overload): Overload of motor and inverter detected by electronic thermal overload protective circuit.	
■ ■ ■	■ ■ ■	OV (Overvoltage): DC bus voltage higher than 790 V.	
■ ■ ■	■ ■ ■	UV1 (Undervoltage): DC bus voltage lower than approx 420V with 6S-⑤ set to ON (F1 blinking for 2 seconds. UV1 indication changed to UV2)	
■ ■ ■	■ ■ ■	UV2 (Undervoltage): DC bus voltage lower than 420 V	
■ ■ ■	□	OH (Heat Sink Overheat): Thermoswitch operated by overheat of heat sink of main circuit semiconductor.	
■ ■ ■	□	EB (External Failure): Fault signal is input from external terminal ⑦.	
■ ■ ■	□	CPF (Control Function Error): Detection of the failure of CPU and main control function by self-diagnostic function.	*
■ ■ ■	■ ■ ■	CPF-SEL (Selection Error): Any one of setting switches (1 S to 6S) changed with power ON	

\* Inverter continues operation When the setting is returned to the state before change, the display replaces the normal operation status

Note Indication status is as follows

□ Light OFF

■ ■ ■ Blinking at equal intervals

■ ■ ■ Blinking at short-long intervals

■ ■ ■ Light ON

## 9. TROUBLESHOOTING

If the VS-616HII malfunctions, find the cause and take the corrective action by following the flow charts given in this section.







If the cause cannot still be located by the flowcharts, the inverter or some parts are damaged, or any other problem occurs, contact Yaskawa representative.

### 9.1 MEASURING POINT AND INSTRUMENT

Since the VS-616HII transistor inverters utilize the PWM control mode, unless specified instruments are used, correct measurement cannot be made.

The measuring points and the measuring instruments are shown in Fig. 20 on page 29 and Table 16.

Table 16 Measuring Points and Instruments

Item	Points	Instrument	Note
Supply Voltage $V_1$	Across R-S (L1-L2), S-T (L2-L3), T-R (L3-L1), $\textcircled{V_R}$ , $\textcircled{V_S}$ , $\textcircled{V_T}$ ( $V_{L1-L2}$ , $V_{L2-L3}$ , $V_{L3-L1}$ )	 Moving-iron type, or rectifier type voltmeter	—
Power Supply Current $I_1$	Line current R, S, T (L1, L2, L3) $\textcircled{A_R}$ , $\textcircled{A_S}$ , $\textcircled{A_T}$ ( $A_{L1}$ , $A_{L2}$ , $A_{L3}$ )	 Moving-iron type	—
Power Supply Power* $P_1$	R, S, T (L1, L2, L3) and across R-S (L1-L2), S-T (L2-L3), T-R (L3-L1) $\textcircled{W_R}$ , $\textcircled{W_S}$ , $\textcircled{W_T}$ ( $W_{L1}$ , $W_{L2}$ , $W_{L3}$ )	 Electro-dynamometer type; Use 3 identical single-phase meters	$P_1 = W_R + W_S + W_T$
Power Supply Power Factor $Pf_1$	Calculate from measured supply voltage, supply current, and supply power $Pf_1 = \frac{P_1}{\sqrt{3} V_1 I_1} \times 100 (\%)$		
Output Voltage $V_2$	Across U-V, V-W, W-U $\textcircled{V_U}$ , $\textcircled{V_V}$ , $\textcircled{V_W}$ ( $V_{T1-T2}$ , $V_{T2-T3}$ , $V_{T3-T1}$ )	 Rectifier type (YOKOGAWA 2017 or equivalent) Moving-iron type cannot be used.	1000 V full scale for 400 V circuit.
Output Current $I_2$	Line current at U, V, W $\textcircled{A_U}$ , $\textcircled{A_V}$ , $\textcircled{A_W}$ ( $A_{T1}$ , $A_{T2}$ , $A_{T3}$ )	 Moving-iron type	—
Output Current $P_2$	U, V, W (T1, T2, T3) and across U-V (T1-T2), V-W (T2-T3), W-U (T3-T1) $\textcircled{W_U}$ , $\textcircled{W_V}$ , $\textcircled{W_W}$ ( $W_{T1}$ , $W_{T2}$ , $W_{T3}$ )	 Electro-dynamometer type, Three identical rating single-phase meters are used.	$P_2 = W_U + W_V + W_W$
Output Power Factor $Pf_2$	Calculated same as power factor on supply side. $Pf_2 = \frac{P_2}{\sqrt{3} V_2 I_2} \times 100 (\%)$		
Frequency Setting Signal	Across $\textcircled{9}$ - $\textcircled{10}$ Across $\textcircled{21}$ - $\textcircled{22}$	 Moving-coil type (Multimeter is OK) (Internal resistance: 50 kΩ max)	0 to 10 VDC
Frequency Monitor	Across $\textcircled{17}$ - $\textcircled{18}$		10VDC at max frequency (without frequency meter)

\* To measure the power, use the power meter incorporating a hall generator  
HIOKI TYPE 3161 Power meter (made by HIOKI Electric, Japan)

The output voltage  $\textcircled{U}$  ( $\textcircled{T1}$ ),  $\textcircled{V}$  ( $\textcircled{T2}$ ),  $\textcircled{W}$  ( $\textcircled{T3}$ ) has been measured with a YOKOGAWA 2017 (rectifier type) voltmeter before shipping.

Fig. 21 on page 29 shows an example of actually measured output voltage. The rectifier type instruments give different readings, depending on type.

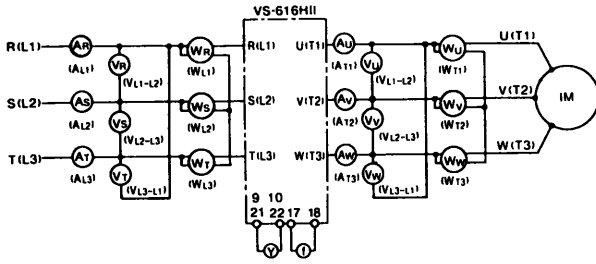

Fig. 20 Points for Measurement

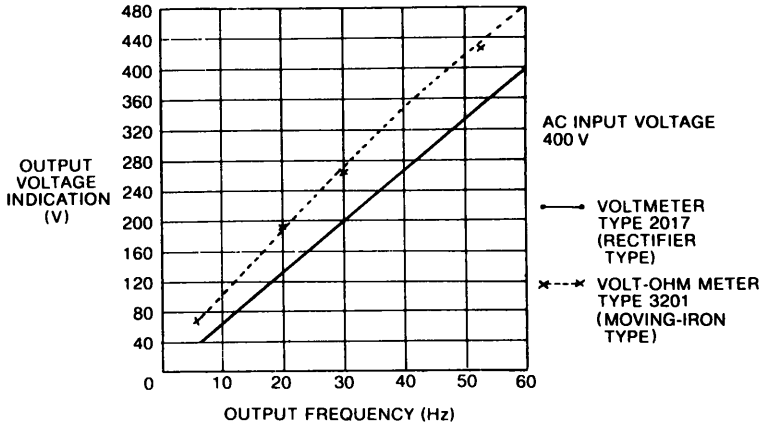
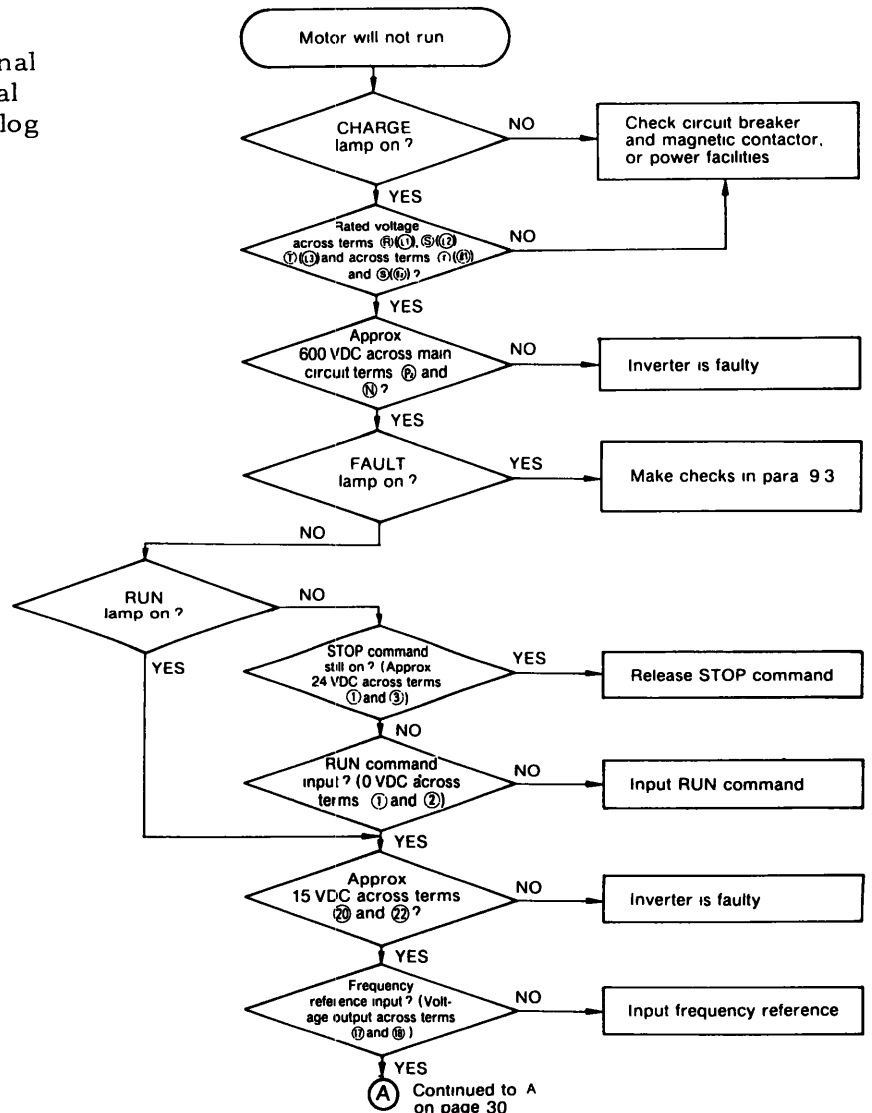
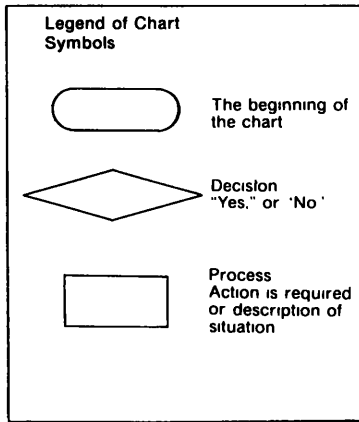

Fig. 21 Output Voltage Measurement

## 9.2 TROUBLESHOOTING FOR MOTOR SYMPTOM

(1) Motor will not run.

For operation from external command through external terminals (Digital or Analog operator not used)



## 9.2 TROUBLESHOOTING FOR MOTOR SYMPTOM (Cont'd)

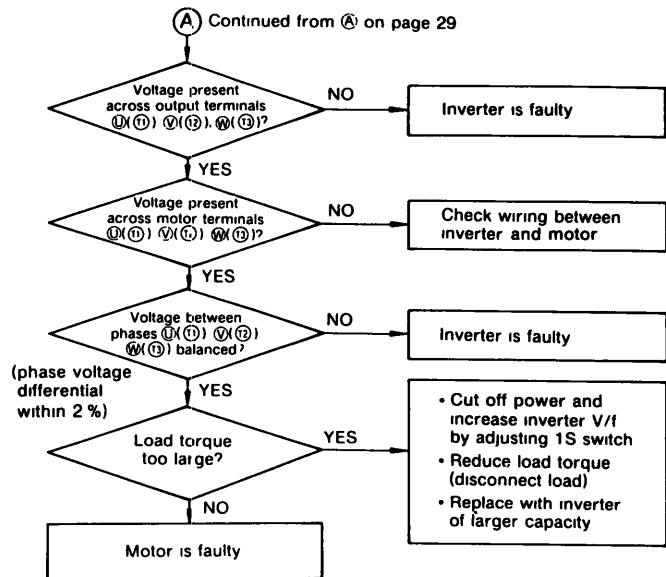

### (2) Motor stalls during acceleration

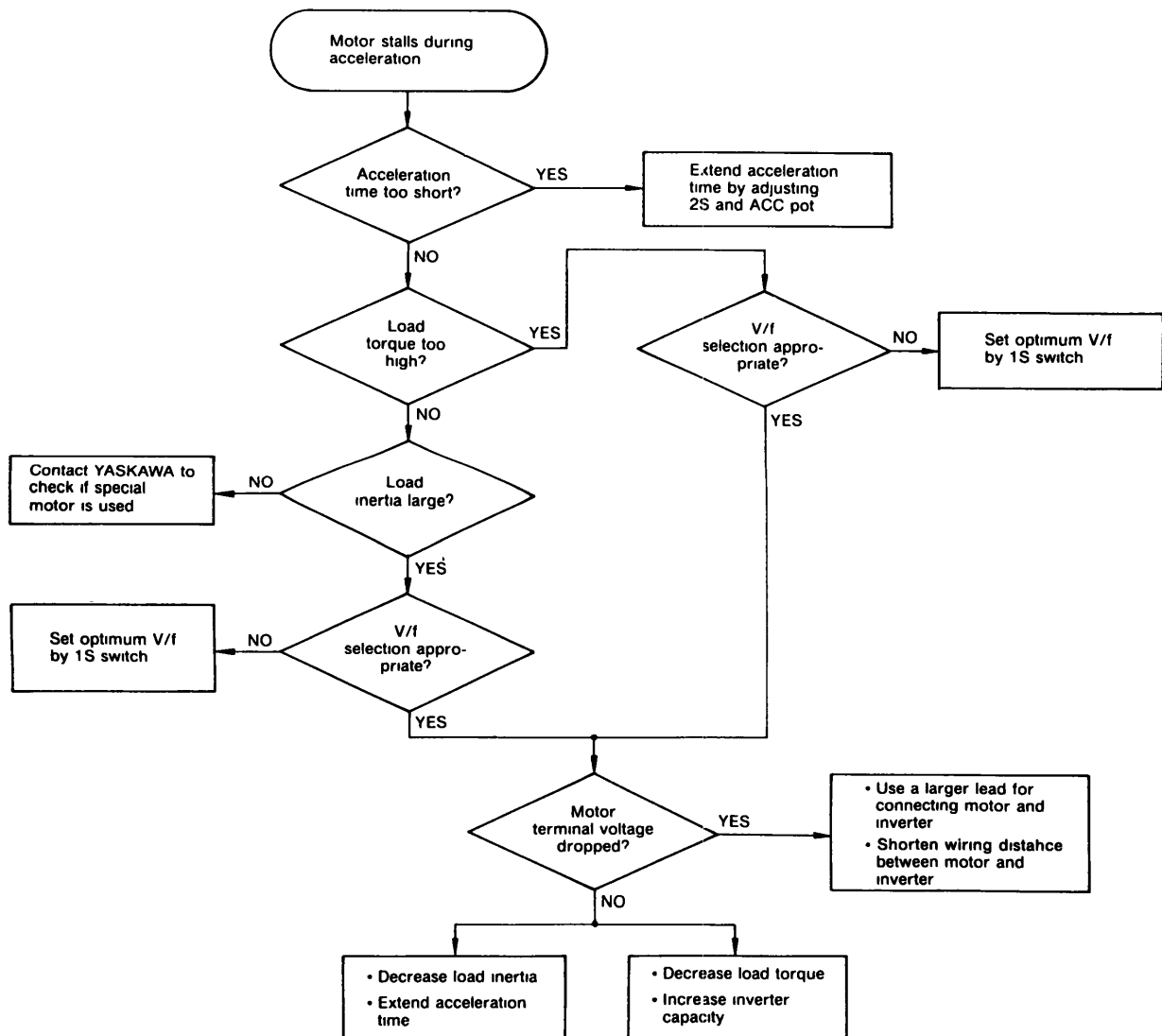

### 9.3 TROUBLESHOOTING FOR FAILURE INDICATIONS

When the inverter protective function works, the malfunctions are detected by failure indicators. Check the cause of the experienced failure and take corrective action. The predictable symptoms are as follows:

- (1) Fuse blown
- (2) Overvoltage of the main circuit DC bus.
- (3) Overcurrents in load.
- (4) Overloaded operation.
- (5) Undervoltage of the main circuit DC bus.
- (6) The inverter overheated.
- (7) The control function went down.
- (8) A fault signal input.

#### (1) Fuse blown (FU) displayed

When the fuse blows, be sure to check the power transistor, even when the cause is on the load side.

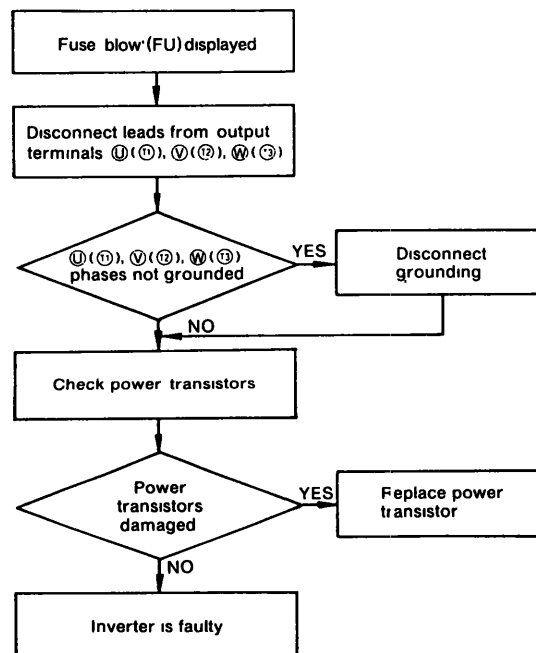

### 9.3 TROUBLESHOOTING FOR FAILURE INDICATIONS (Cont'd)

#### (2) Overvoltage (OV) indication

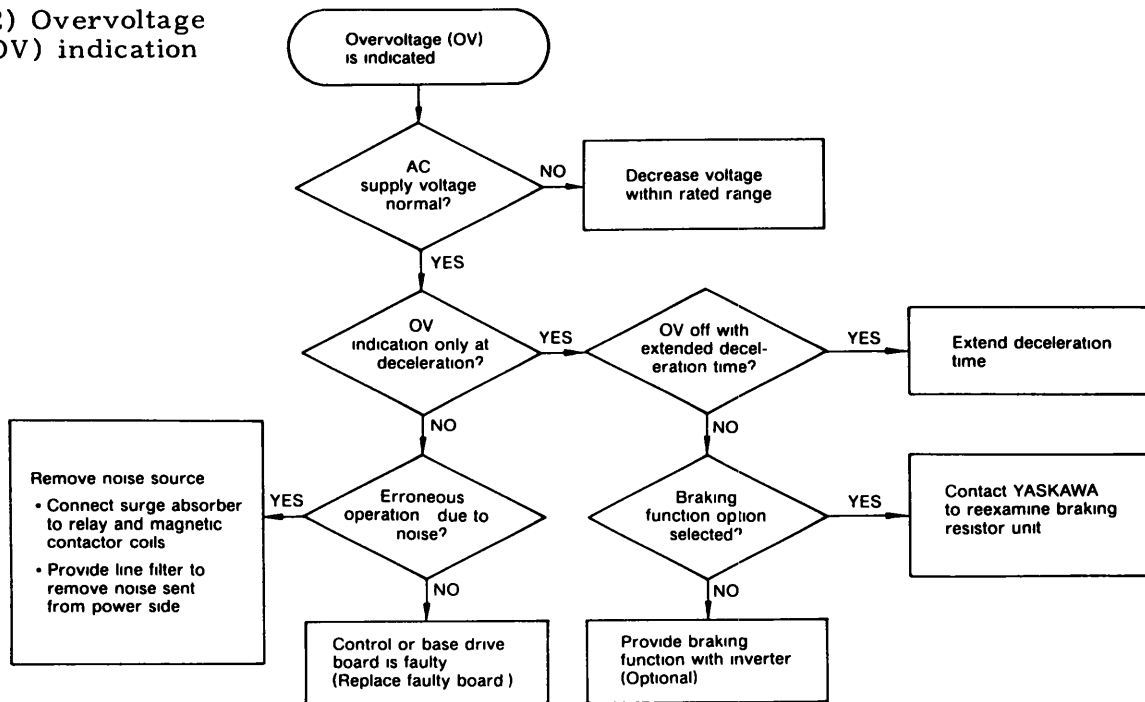

#### (3) Overcurrent (OC) indication

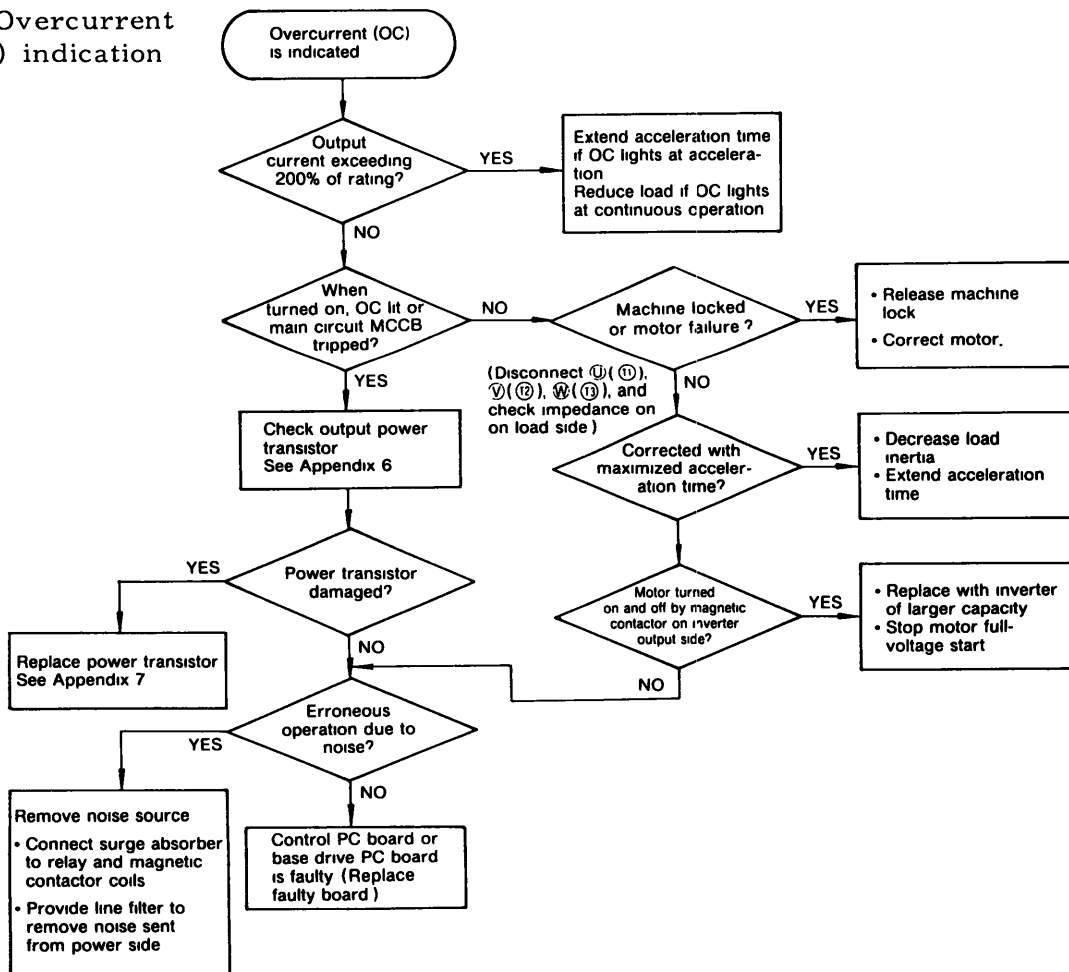



(4) Overload (OL) indication

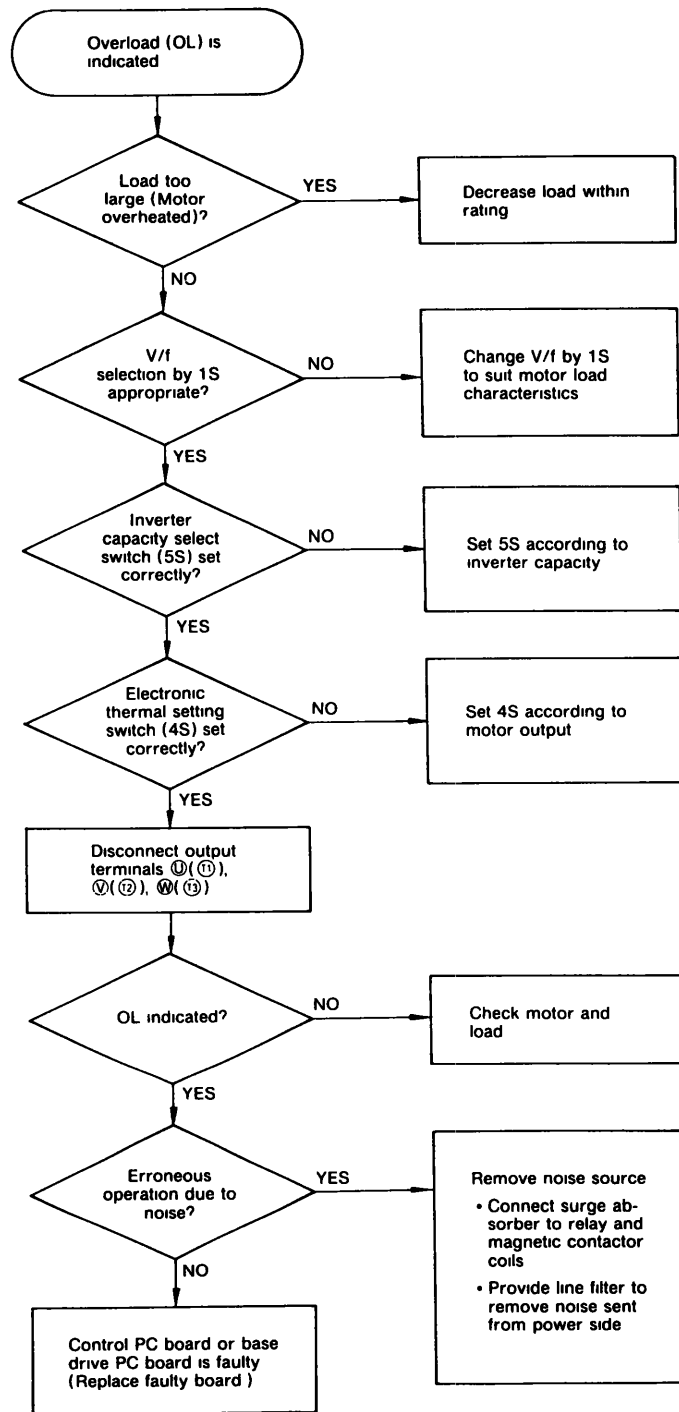

### 9. 3 TROUBLESHOOTING FOR FAILURE INDICATIONS (Cont'd)

#### (5) Undervoltage (UV) indication

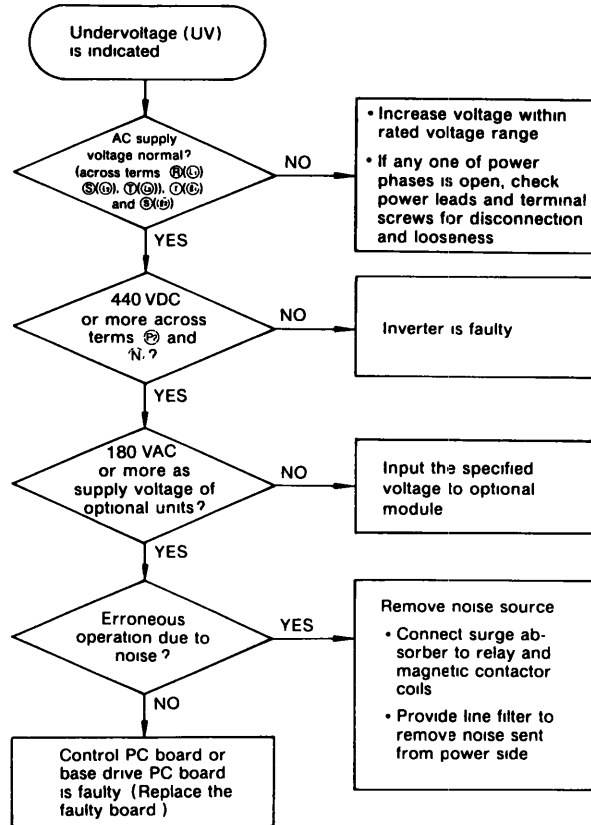

#### (6) Inverter overheat (OH) indication

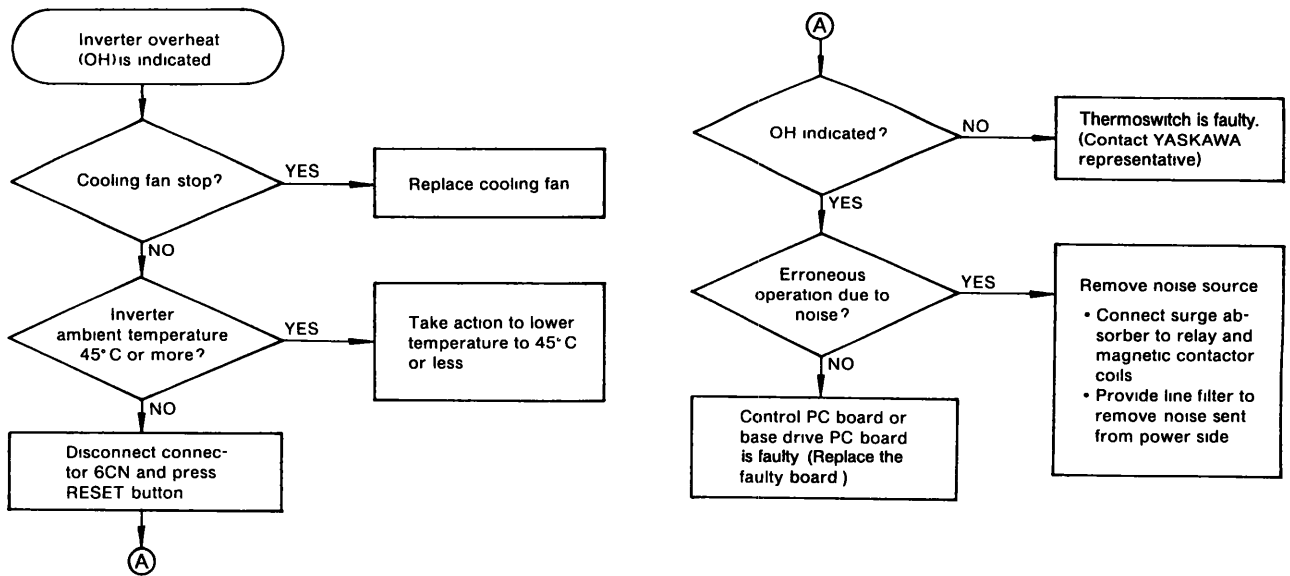

(7) CPF indication

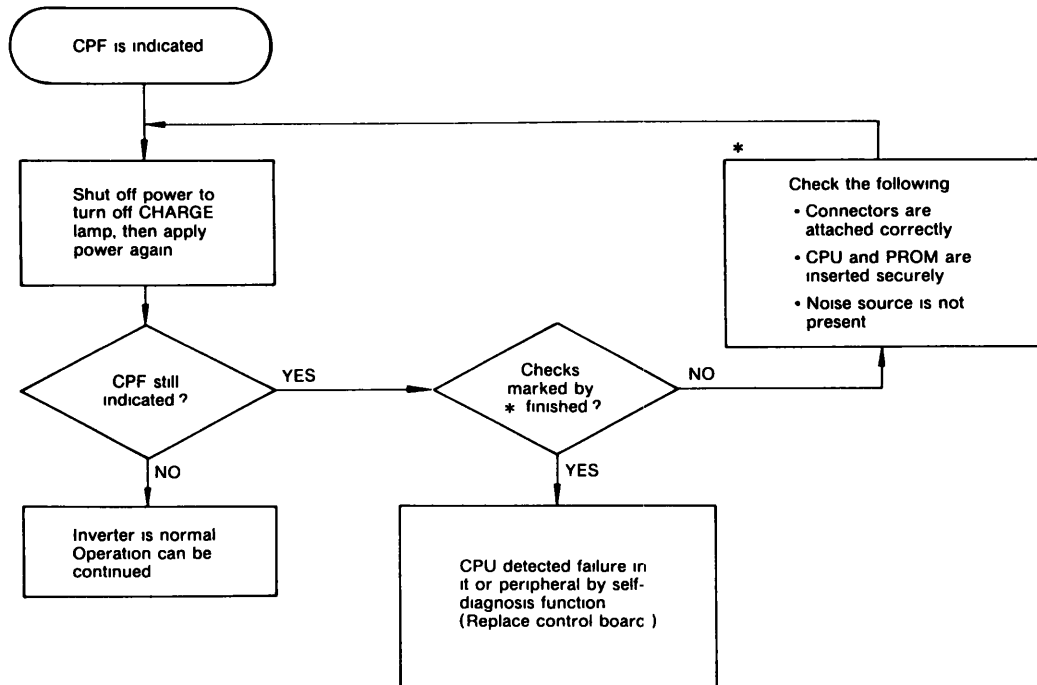

(8) EB indication

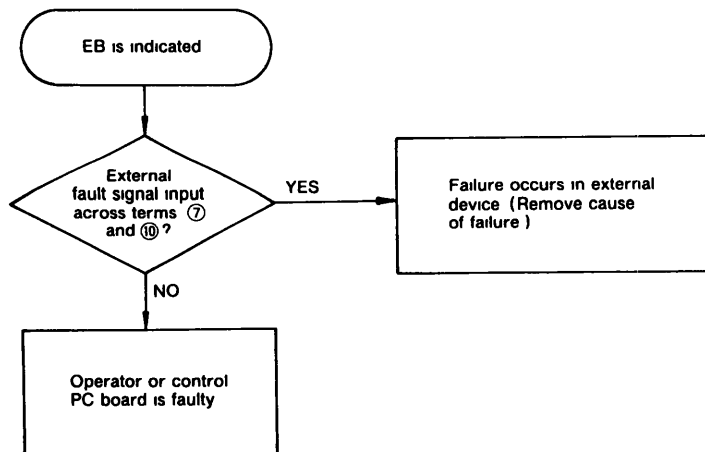

# APPENDIX 1 VS-616HII RATINGS AND SPECIFICATIONS

Table 17 VS-616HII Ratings and Specifications

Inverter Model CIMR-[]		H220B	H300B
Output Characteristics	Max Applicable Motor Output* kW (Hp)	220 (300)	300 (400)
	Inverter Capacity kVA	300	400
	Rated Output Current A	450	600
	Rated Output Voltage	3-Phase, 380/400/415/440/460 VAC	
	Rated Output Frequency	50, 60, 72, 90, 120, 180Hz (Up to 396Hz available as an option)	
Power Supply	Rated Input Voltage and Frequency	3-Phase, 380/400/415/440/460 V, 50/60 Hz	
	Allowable Voltage Fluctuation	Within $\pm 10\%$	
	Allowable Frequency Fluctuation	Within $\pm 5\%$	
Control Characteristics	Control Method	Sine wave PWM	
	Frequency Control Range	40 : 1	
	Frequency Accuracy	Digital command 0.01% (-10 to 40°C, 14 to 104°F), Analog command 0.2% (25°C $\pm$ 10°C, 77 $\pm$ 50°F)	
	Frequency Setting Resolution	Digital input...with digital operator: 0.1Hz, with precision controller: 0.004Hz/60Hz Analog input...with analog operator: 0.06Hz/60Hz, with high precision AD converter: 0.004Hz/60Hz	
	Overload Capacity	150% for one minute	
	Frequency Setting Signal	0 to 10 VDC (20 k $\Omega$ ), 4-20 mA (500 $\Omega$ )	
	Accel/Decel Time	Approx. 0.1 to 1800 sec, 6 ranges selectable, Accel/Decel time set independently	
	Efficiency	Approx. 95%	
	Braking Torque	20% (100% provided with braking module and braking resistor unit: 10% duty cycle)	
	No. of V/f Patterns	15 in total: 4 For general purpose, 4 For high starting torque, 4 For fans and pumps, 3 For machine tools	
Protective Functions	Motor Overload Protection	Electronic thermal overload relay†	
	Instantaneous Overcurrent	Motor coasts to a stop at approx. 200% rated current	
	Overload	Motor coasts to a stop at 150% load for 1 minute	
	Overvoltage	Motor coasts to a stop if converter output voltage exceeds 790 V	
	Undervoltage	Motor coasts to a stop if converter output voltage drops to 420 V or below	
	Momentary Power Failure	Coasts to a stop by momentary power failure detection. (Continues system operation during power failure less than 2 sec by setting on notch ⑤ of 6S switch.)	
	Fin Overheat	Thermostat (trips at the fin temperature of approx. 90°C)	
	Stall Prevention	Stall prevention at acceleration/deceleration and constant-speed operation	
	Power Charge Indication	Charge lamp keeps ON until converter output voltage drops below 50 V	
Environmental Condition	Location	Indoor (protected from corrosive gases and dust)	
	Ambient Temperature	-10 to +40°C, +14 to +104°F (not frozen)	
	Storage Temperature†	-20 to +60°C, -4 to +140°F	
	Humidity	90% FH (no condensation)	
Vibration	1 G less than 20 Hz, up to 0.2 G at 20 to 50 Hz		
Approx. Weight	kg (lbs)	1300 (2865.96)	
Dimensions mm (in.)	Width	1615 (63.58)	
	Height	2580 (101.57)	
	Depth	800 (31.50)	

\* For standard motors rated 4 poles

† Protects motors having the torque characteristics shown below

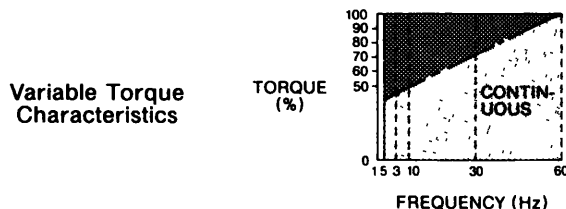

Yaskawa Motors  
(Dashed line shows continuous operation range)

† Temperature during shipping. Storing in this temperature for a long period may deteriorate main circuit capacitor. Contact Yaskawa representative.

## APPENDIX 2 TERMINAL FUNCTIONS

Table 18 Terminal Functions and Voltages of Main Circuit

Terminals	Functions	Levels
W R (L1) S (L2) T (L3)	Main circuit input power supply	3-phase 380/400/415/440/460/ VAC at 50/60 Hz (Voltage fluctuation $\pm 10\%$ )
r (L1) s (L2) t (L3)	Control circuit and cooling fan input power supply	—
U (T1) V (T2) W(T3)	VS-616HII output	3-phase 380/400/415/440/460 VAC (Proportional to input voltage)
P <sub>1</sub> , P <sub>2</sub>	DC reactor for power factor correction	—
P <sub>3</sub> , N	External capacitor	Approx 600 VDC
P <sub>1</sub> , N	Braking unit	0 or Approx 600 VDC
P <sub>2</sub> , N	Main circuit DC power supply	Approx 600 VDC
r <sub>1</sub> , s <sub>1</sub>	Power supply to external equipment	220 VAC, 50/60 Hz
E	Ground terminal	—

Table 19 Terminal Functions and Signals of Control Circuit

Terminals	Functions	Levels	
1	Sequence control input common terminal	Sequence control input 0 V	
2	Run signal	Run at closed*	
3	Stop signal	Stop at open†	
4	Connection to shield sheath of signal lead	—	
5	Forward/Reverse operation selector	Forward at open†, Reverse at closed*	
6	Master/Aux frequency reference selector	Master speed at open†, Aux at closed	
7	External fault input	Fault at closed*	
8	Fault reset input (external)	Fault reset at closed*	
9	Master speed frequency reference input	0 to +10 V (20 k $\Omega$ ) or 4–20 mA (500 $\Omega$ )	
10		0 V	
11	Connection to shield sheath of signal lead	—	
12	Run contact output† (1NC)	Contact capacity: 250 VAC at 1A or below 30 VDC at 1A or below	
13			Open† during run
14			Common
15	Fault contact output (1NONC)	Closed* at fault	Contact capacity: 250 VAC at 1A or below 30 VDC at 1A or below
16		Open† at fault	
17	Frequency meter input	Approx +10 V/100 %, output impedance 3 k $\Omega$	
18		0	
19	Connection to shield sheath of signal lead	—	
20	Aux frequency input	+15 V (VS-616HII internal power supply)	
21		+10 V/100 %	
22		0 V	

\*Short-circuited with terminal ①

†Opening terminal

‡Used as a zero-interlock contact With notches ① and ② of

operation mode selector switch 6S set OFF, RUN contact is on at RUN command and off after DB operation at STOP command



## A3-2 INTERCONNECTION DIAGRAMS FOR VS-616HII APPLICATIONS

### (1) WITH ANALOG OPERATOR

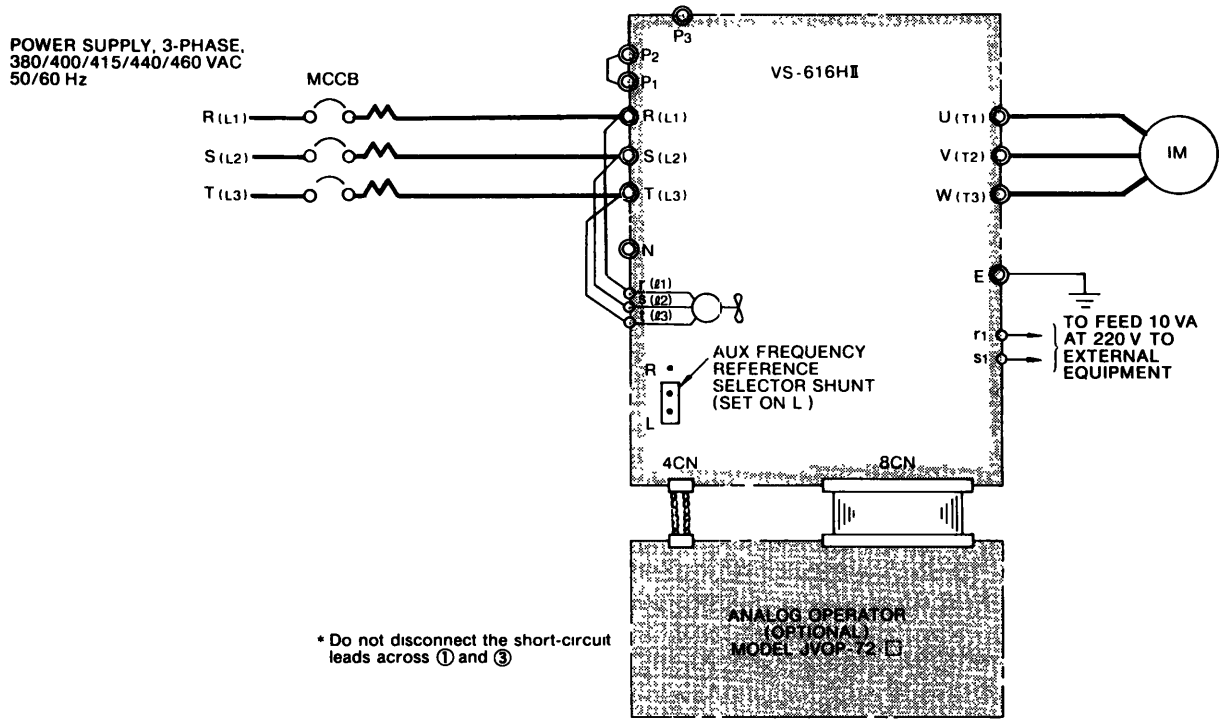

Fig. 23 With Analog Operator

### (2) WITH DIGITAL OPERATOR

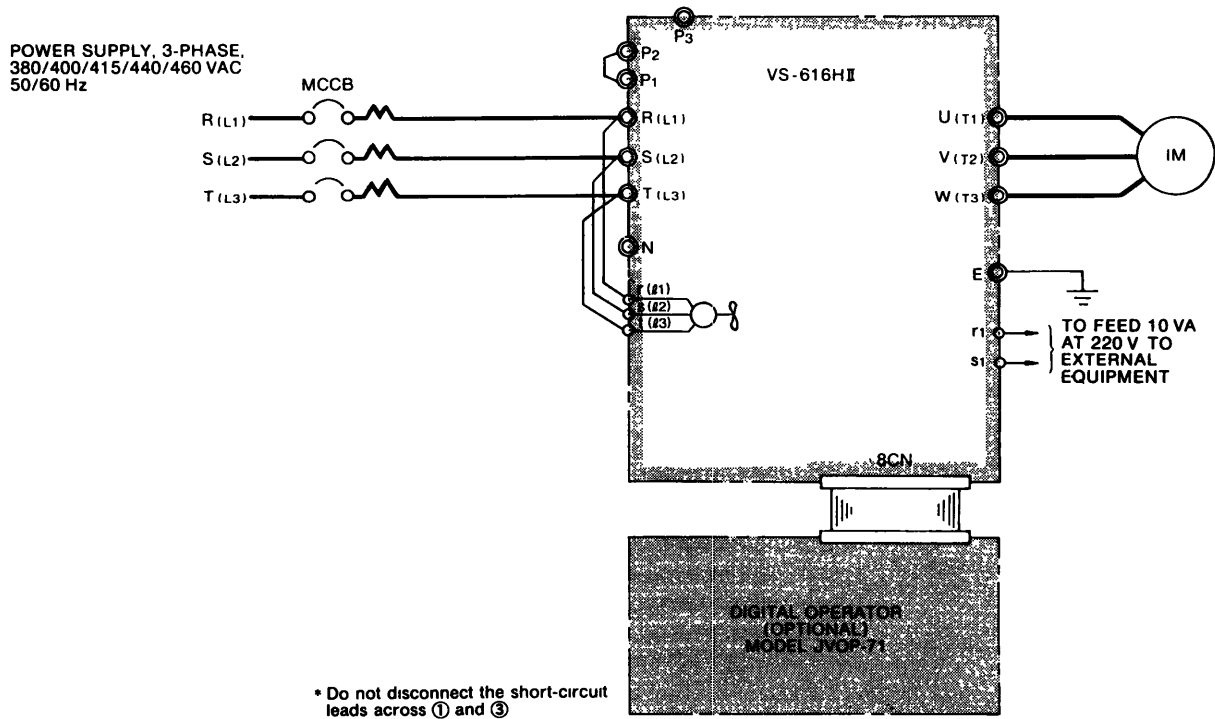
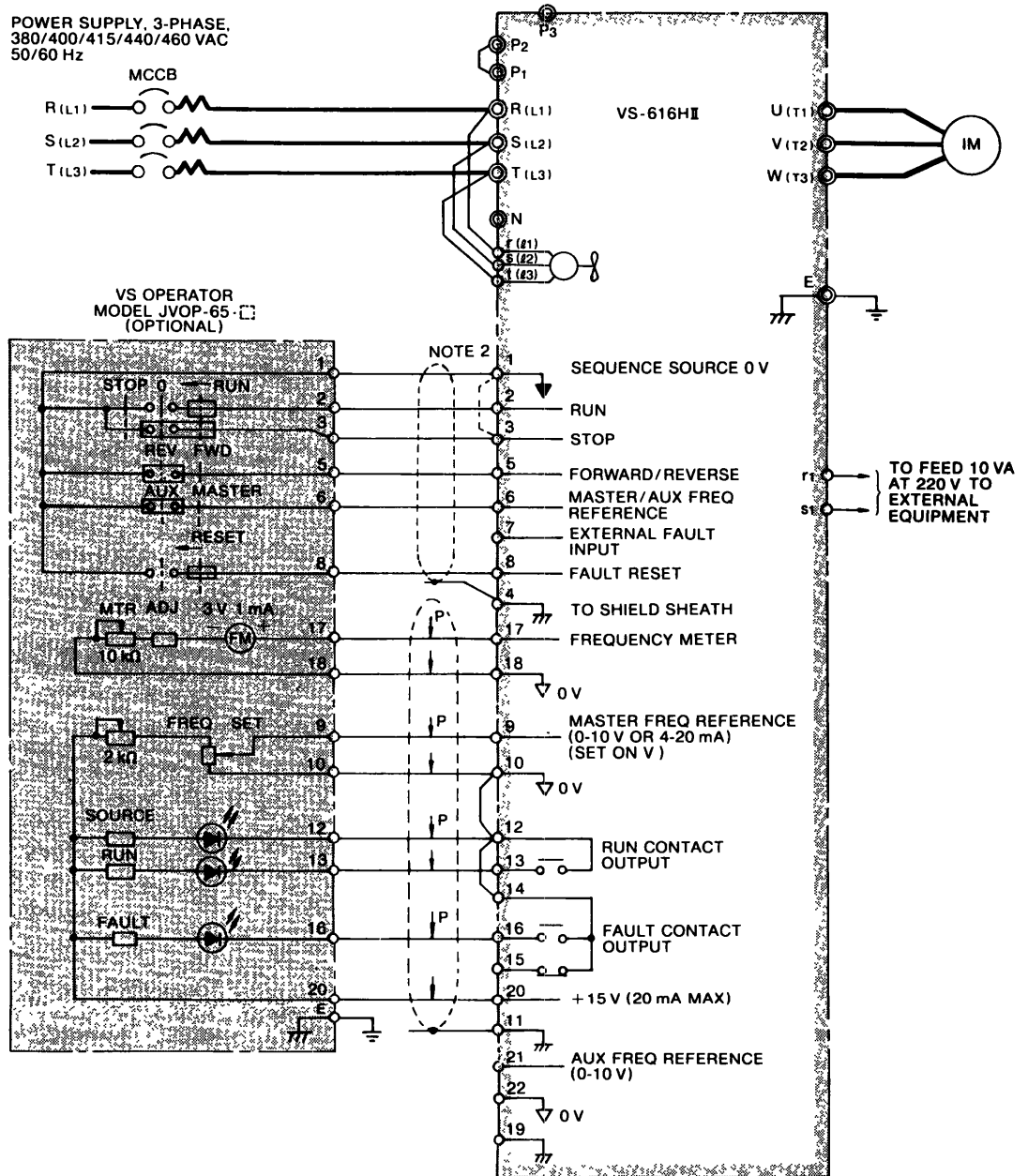

Fig. 24 With Digital Operator

## A3-2 INTERCONNECTION DIAGRAMS FOR VS-616HII APPLICATIONS (Cont'd)

### (3) WITH VS OPERATOR



**Note**

- 1 To give frequency reference from VS operator, set the VS operator MASTER/AUX switch to MASTER
- 2 Remove the short-circuit leads across ① and ③

Fig 25 With VS Operator



(4) WITH USER-ARRANGED OPERATION CIRCUIT

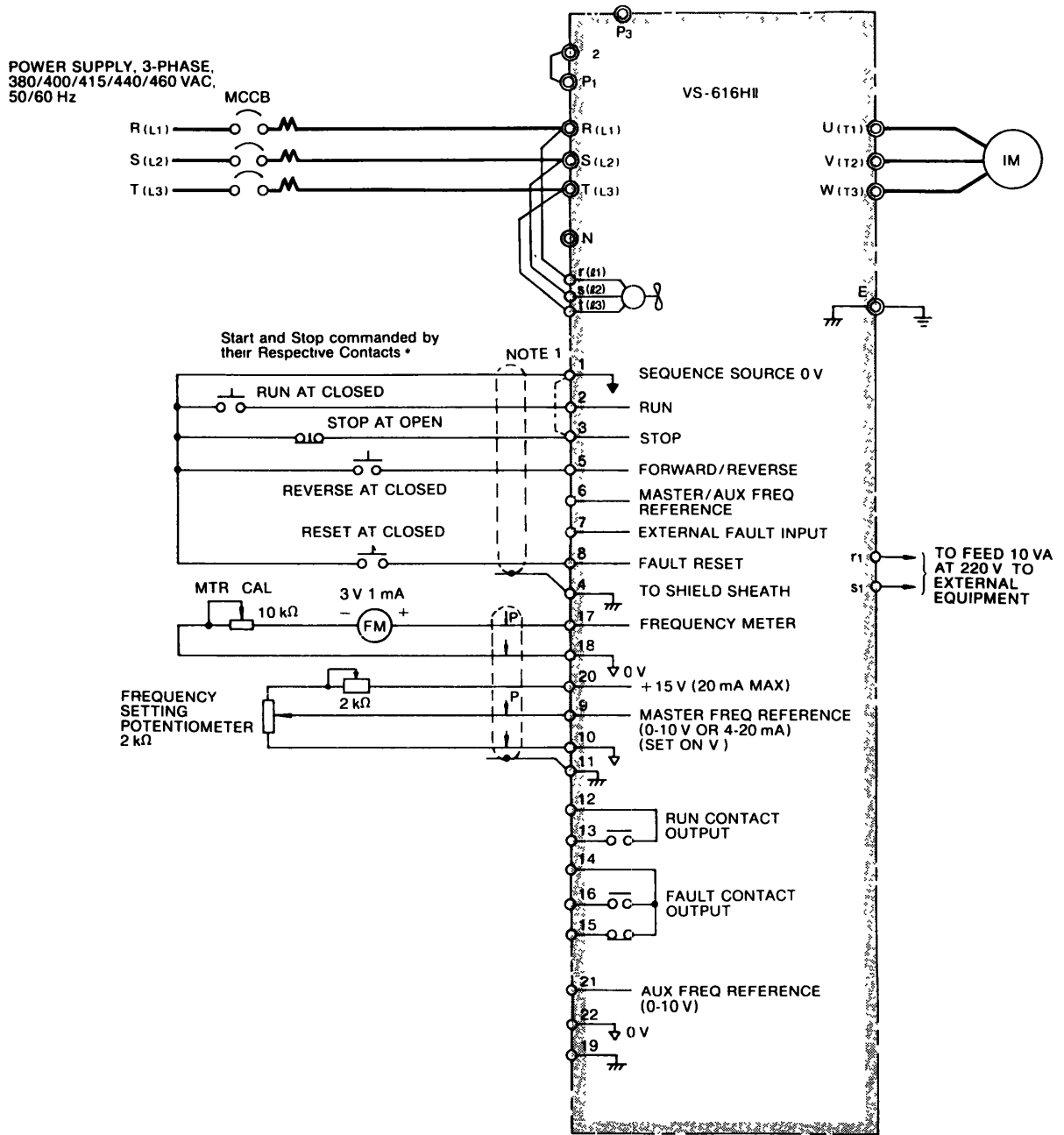

Note

- 1 Remove the short-circuit lead across external terminals ① and ③
- 2 Use RUN terminal ② to stop or start the motor

Fig. 26 With User-Arranged Operation Circuit

\*Start and Stop commanded by a Single Contact

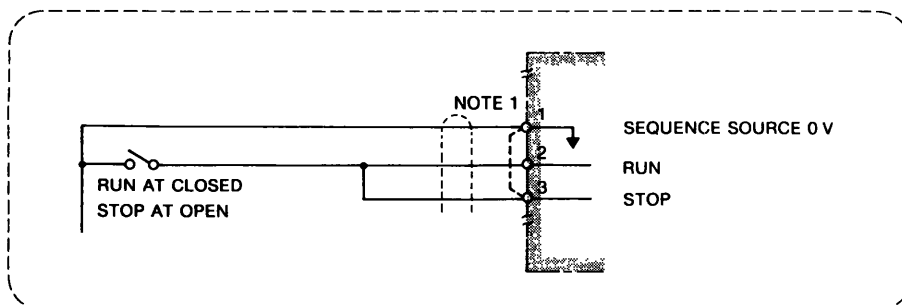

### A3-2 INTERCONNECTION DIAGRAMS FOR VS-616HII APPLICATIONS (Cont'd)

#### (5) WITH MAGNETIC CONTACTOR FOR START/STOP OPERATION

##### (a) Magnetic contactor opened at inverter fault

Before turning on AC main circuit power, be sure the motor is at rest. For frequent turning start/stop operations, this drive circuit is not recommended.

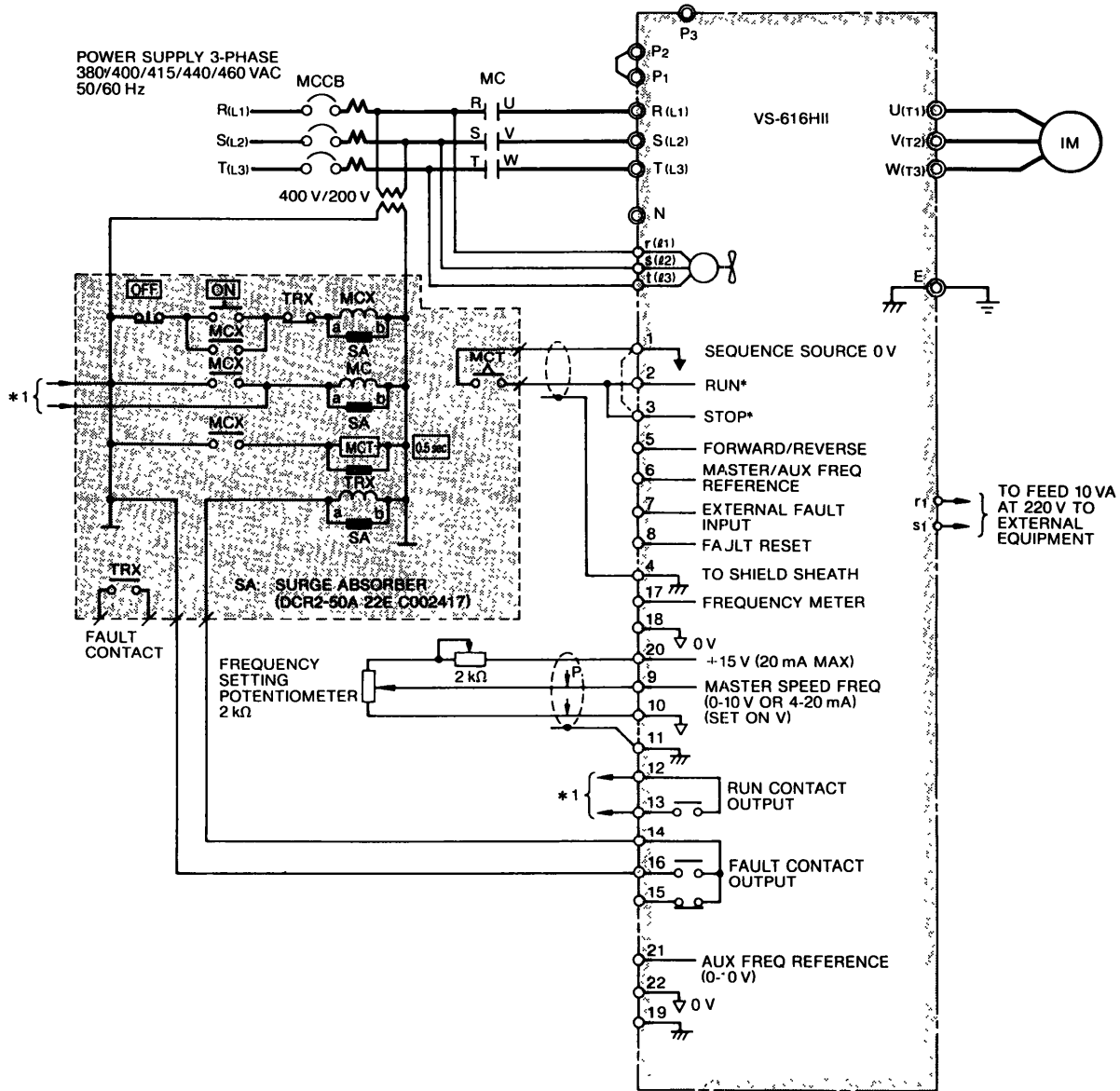

Fig 27 With Magnetic Contactor for Start/Stop Operation (a)

\*Set on notch ② of operation mode selector switch 6S (stopping free-run motor)

Note Remove the short-circuit lead across external terminals ① and ③

(b) Magnetic contactor not opened at inverter fault

Before turning on AC main circuit power, be sure the motor is at rest. For frequent start/stop operations, this drive circuit is not recommended.

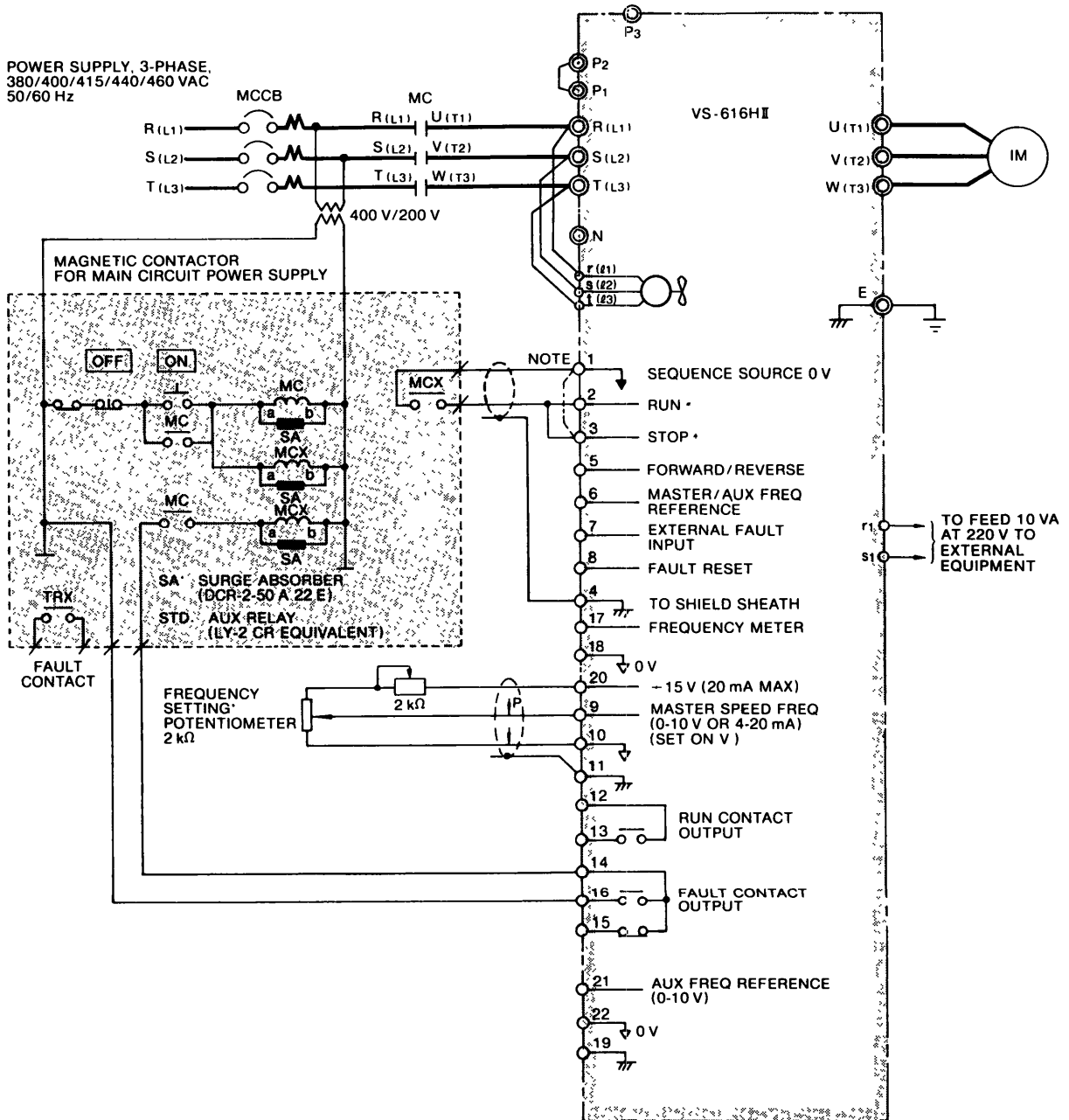

\*Set on notch ② of operation mode selector switch 6S (stopping free-run motor)

Note. Remove the short-circuit lead across external terminals ① and ③

Fig 28 With Magnetic Contactor for Start/Stop Operation (b)

## A3-2 INTERCONNECTION DIAGRAMS FOR VS-616HII APPLICATIONS (Cont'd)

### (6) WITH VS OPERATOR AND ANALOG OPERATOR

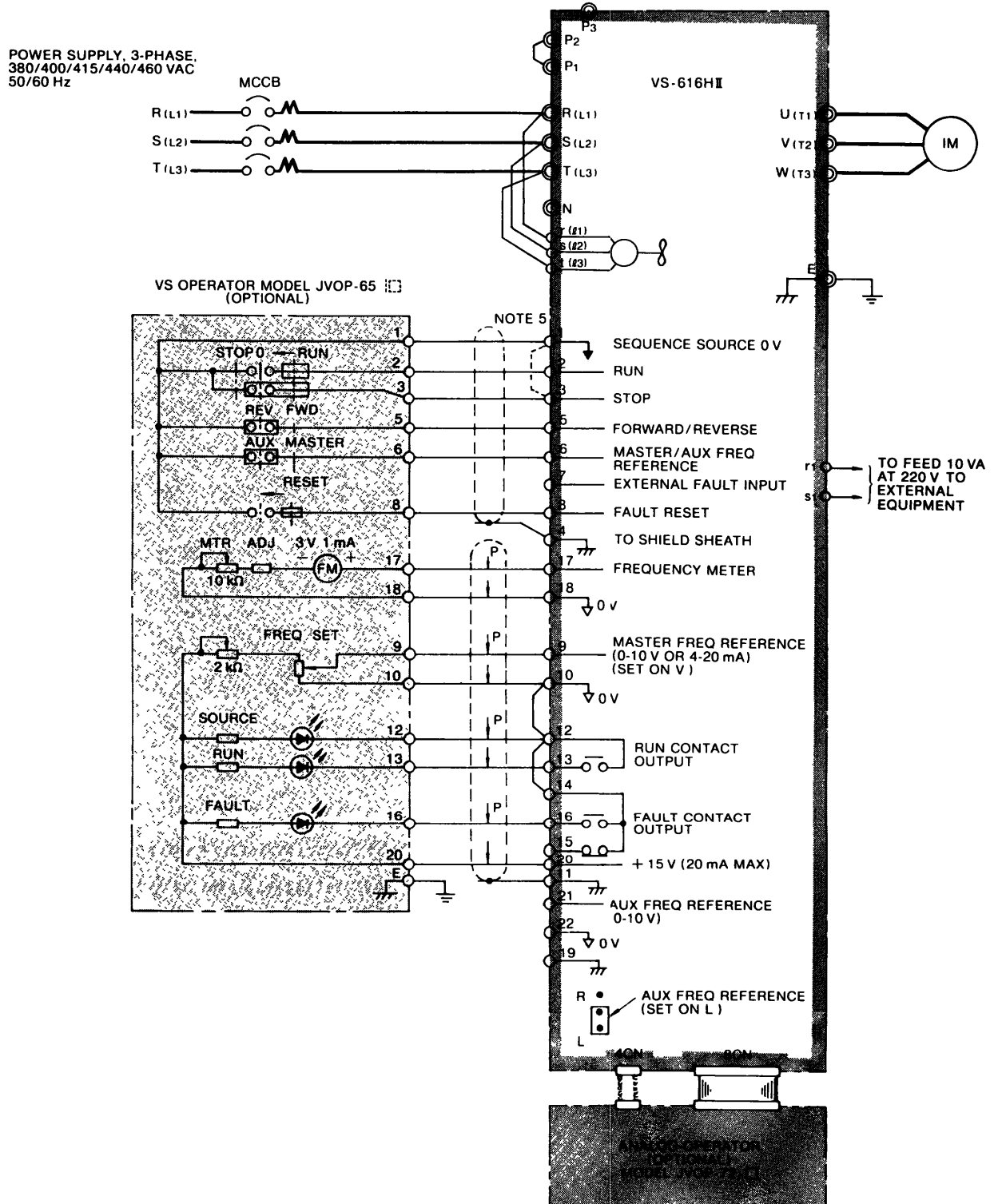

#### Note

- 1 To give the frequency reference from VS operator, change the Analog operator AUTO/MAN switch to AUTO and VS operator MASTER/AUX switch to MASTER
- 2 To give the frequency reference from Analog operator, set the AUTO/MAN switch to MAN
- 3 Use of Analog operator does not permit the use of auxiliary frequency reference terminal ⑦
- 4 Stop operation can be made by either VS operator or Analog operator Stop command Either stop command takes priority over any command
- 5 Disconnect the short-circuited terminals ① and ③

Fig. 29 With VS Operator and Analog Operator

(7) WITH VS OPERATOR AND DIGITAL OPERATOR

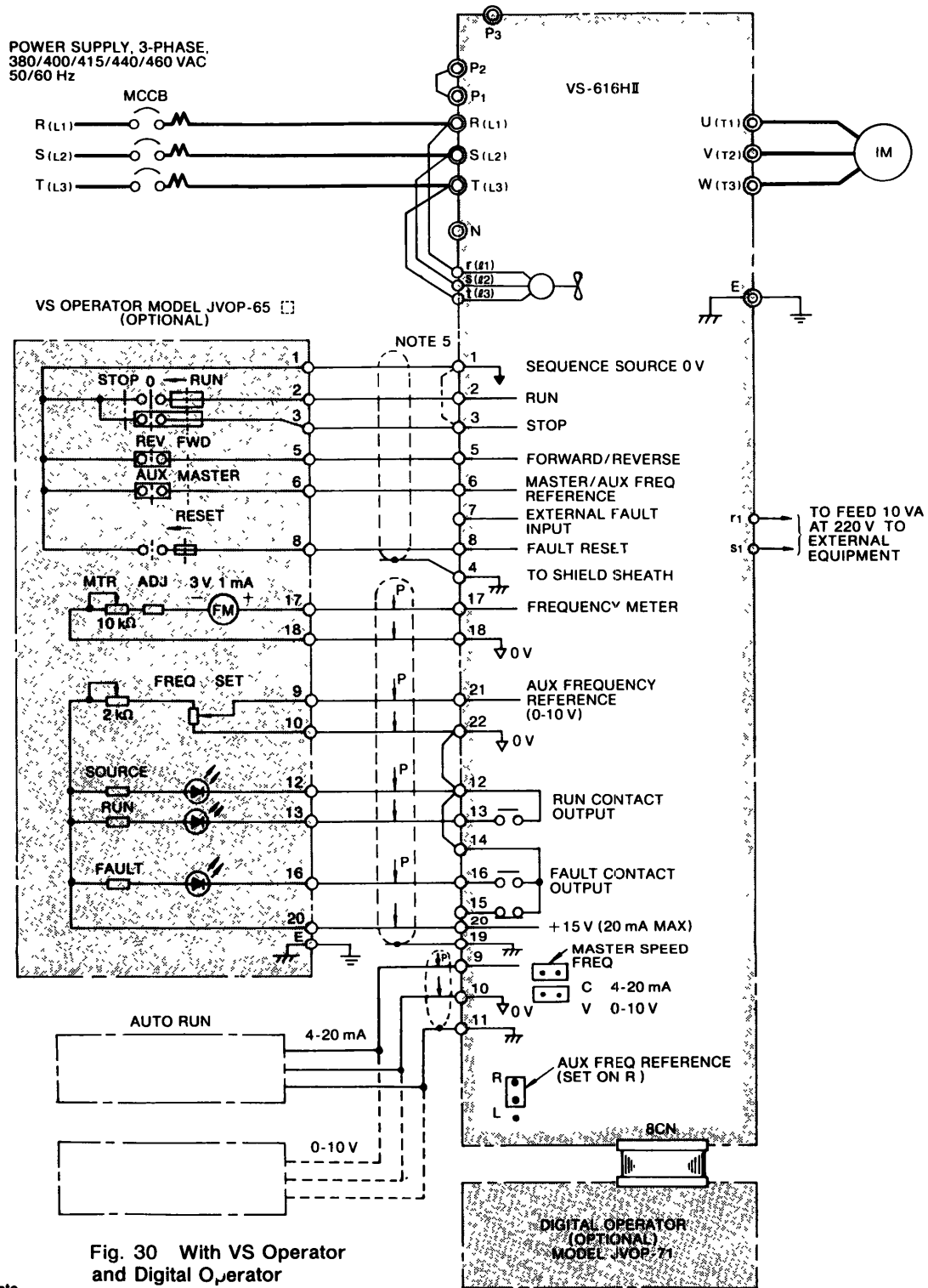

Note

1. To give frequency reference from VS operator.
  - Change Digital operator switch to AUTO
  - Change VS operator MASTER/AUX switch to AUTO
2. To give frequency reference through automatic operation command.
  - Change the Digital operator switch to AUTO.
  - Change the VS operator MASTER/AUX switch to MASTER
  - For voltage reference of 0 to 10 V, set the MASTER SPEED FREQUENCY shunt on (V) and for current reference of 4 to 20 mA, set it on (C)
3. To set frequency reference from Digital operator, set the Digital operator switch to MAN. Switching frequency reference from Digital operator to the other devices can be made at motor standstill only.
4. Stop operation can be made by either VS operator or Digital operator. Either stop command takes priority over any command.
5. Disconnect the short-circuited terminals ① ③

**A3-2 INTERCONNECTION DIAGRAMS FOR VS-616HII APPLICATIONS (Cont'd)**

**(8) WITH BRAKING UNIT AND BRAKING RESISTOR UNIT**

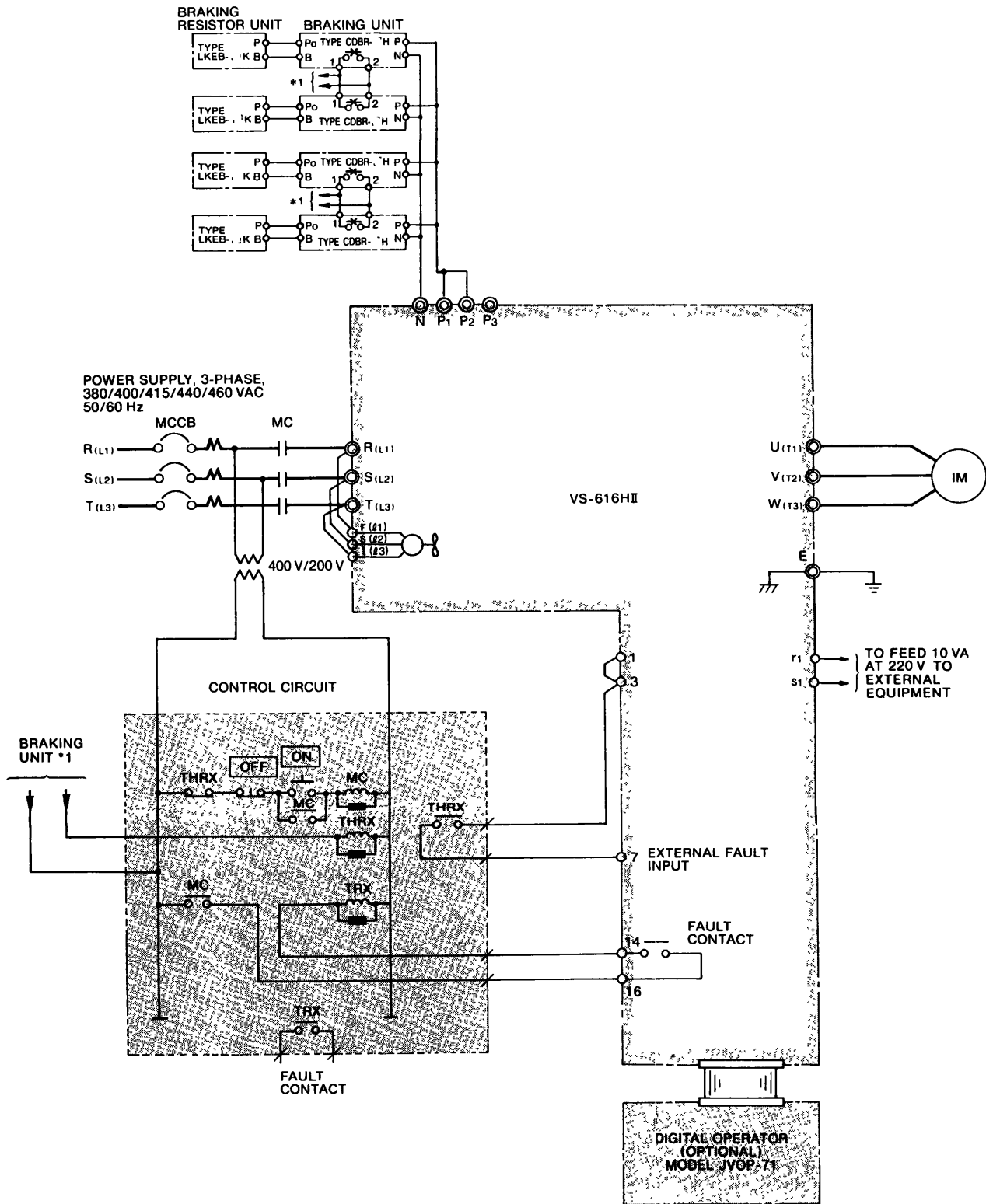

**Fig. 31 With Braking Unit and Braking Resistor Unit**

(9) WITH TRANSISTOR (OPEN COLLECTOR) USED AS OPERATION COMMAND SIGNAL

Relay contacts or transistors (open collector) used as operation command signal should be specified as follows.

Relay Contact:

Contact Capacity - 30 VDC minimum

Rated Current - 100 mA minimum

Transistor (Open Collector):

Withstand Voltage - 35 VDC minimum

Rated Current - 100 mA minimum

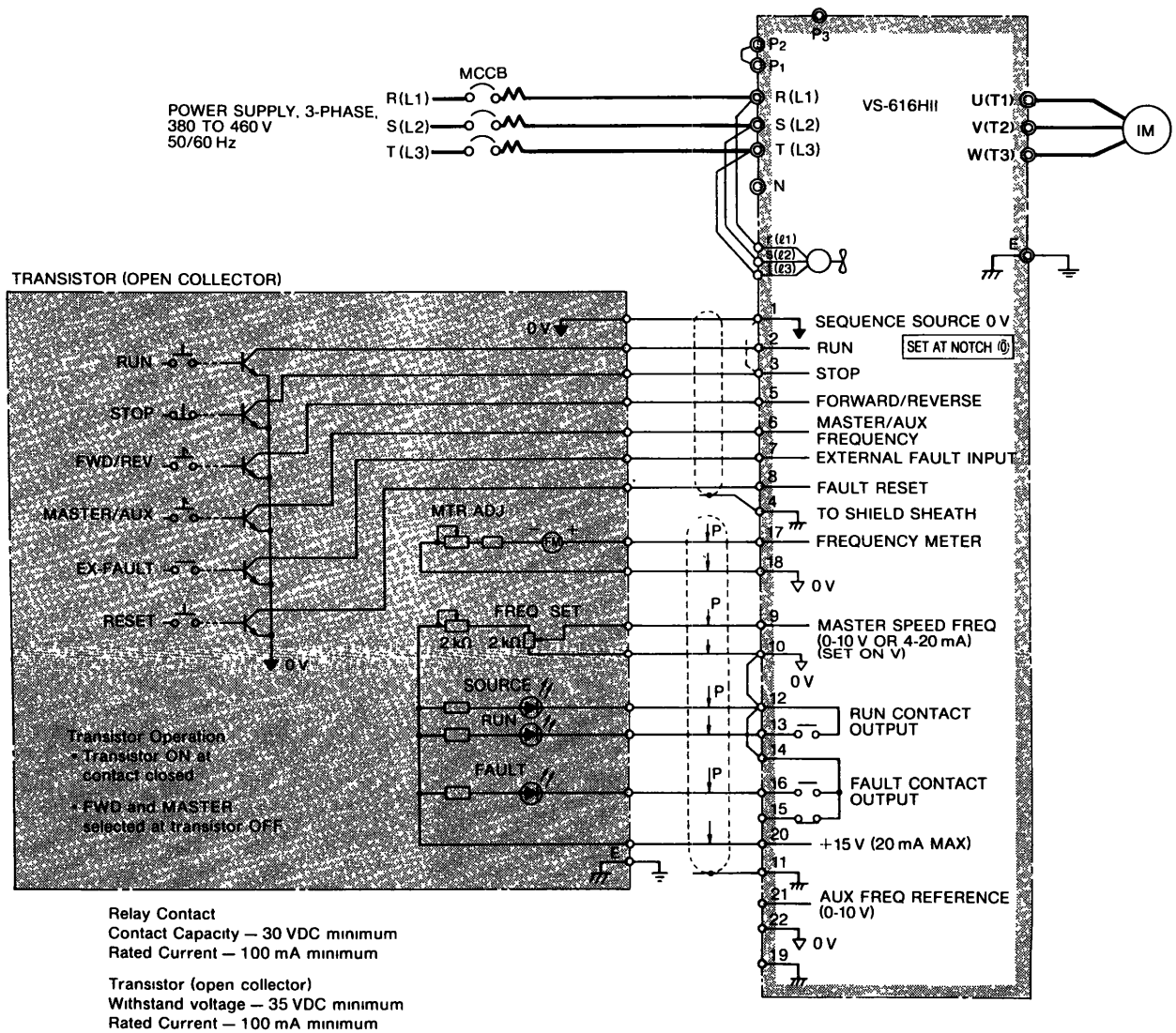

Fig 32 With Transistor (Open Collector) used as Operation Command Signal

# APPENDIX 4 VS-616HII OPTIONAL AND AUXILIARY UNITS

## A4-1 VS-616HII OPTIONAL UNITS

Table 20 VS-616HII Optional Units

Name	Model	Code No.	Functions
Digital Operator	JVOP-71	73041-0701X	Mounted on the inverter. Issues operation commands, sets the frequency by the digital signal, and displays the preset or current frequency in digital form Also, displays the type of fault in characters when a failure occurs
Analog Operator	JVOP-72-□□*	73041-0702X-□□□□*	Mounted on the inverter. Gives operation commands, sets the frequency by the analog signal, and indicates the current frequency on the frequency meter.
VS Operator	JVOP-65-□□*	73041-0703X-□□□□*	Used for remote operation. Outputs operation commands, sets the frequency by analog commands, and indicates the current frequency on the frequency meter.
Braking Unit	CDBR-H45H	EUJ00645X	If the main circuit DC voltage exceeds a specified level during motor regeneration, it causes the braking resistor to absorb regeneration energy.
Braking Resistor Unit	LKEB-H10.8K	EUX00205X	Absorbs regeneration energy of the motor, enhancing the inverter braking capability

\*Code No and model name suffixes indicate the type of frequency meter as shown below

Note: For other optional units except the above, refer to catalog KAE-S616-40E

### • Analog Operator

Model JVOP-72-□□		Code No. 73041-0702X-□□□□	
Frequency Meter Max Scale	60/120 Hz	1	01
	72 Hz	4	04
	90/80 Hz	5	05
	240 Hz	8	08
	360 Hz	9	09

### • VS Operator

Model JVOP-65-□□		Code No. 73041-0703X-□□□□	
Frequency Meter Max Scale	75 Hz	1	01
	150 Hz	2	02
	220 Hz	3	03



## A4-2 VS-616HII AUXILIARY UNITS

Table 21 VS-616HII Auxiliary Units

Name	Function
Main Circuit Magnetic Contactor	Switches on and off the main circuit, and interlocks the circuit if a failure occurs.
Molded-case Circuit Breaker (MCCB)	Protects the main circuit wiring and inverter from damage caused by short-circuit current.
AC Reactor	Improves the high-frequency content of the power or prevents mutual interference due to voltage waveform distortion when connected to the power side. Beters the current waveform, lowers noise and increases the motor torque when connected to the output of the inverter.
Noise Filter	<ul style="list-style-type: none"> <li>• Suppresses transmission of high-frequency noise produced by the inverter to the power side (input noise filter).</li> <li>• Suppresses transmission of high-frequency noise produced by the inverter to the motor (output noise filter).</li> </ul>
Thermal Overload Relay	Protects the motors from burning when two or more motors are operated by one inverter
Ground Fault Interrupter	Detects degradation in main circuit insulation, and shuts off the main circuit. (Set the Setting to 200 mA, and the operating time to 0.2 sec or more.)
Surge Absorber	Prevents problems due to noise when connected coils of the relays, magnetic contactors, magnetic valve, and so on (DCR2-50A22E or -10A25C) (If power waveform distortion is serious, contact YASKAWA representative.)
Frequency Setting Potentiometer	Variable resistor used to set the analog frequency. (2 k $\Omega$ , 0.5 W or more).
Frequency Meter Calibration Potentiometer	Calibrates the maximum indication value of the frequency meter. (10 k $\Omega$ , 0.25 W or more).
Frequency Meter	Indicates the output frequency of the inverter. (3 V, 1 mA at full scale).

Note: For other auxiliary units except the above, refer to catalog KAE-S616-40E

Table 22 Devices of VS Operator Model JVOP-65-□

Device	Model	Specifications	Part Code	
Frequency Meter	DCF-6A	3 V, 1 mA	75 Hz at full scale	FM 000067
			150 Hz at full scale	FM 000069
			220 Hz at full scale	FM 000072
Frequency Setting Potentiometer	RV30YN 20S-HV	2 k $\Omega$ , 1 W	RH 000649	

# APPENDIX 5 CHECKING OF DIODE AND TRANSISTOR MODULES

## A5-1 DIODE MODULE

Measure the resistance across the module terminals with a volt-ohm meter. Use the meter by setting at  $\times 1\Omega$  range. The measured resistance should be within the reference value listed in Table 23.

Table 23 Diode Module Resistances

Diode Module Terminals		Reference Resistances	Abnormal Resistances	Diode Terminals
VOM Terminal $\ominus$	VOM Terminal $\oplus$			
K	A	$\infty$	Several 10 ohms max	A $\rightarrow$ K
A	K	Several 10 ohms max	$\infty$ or $0\Omega$	A Anode K Cathode

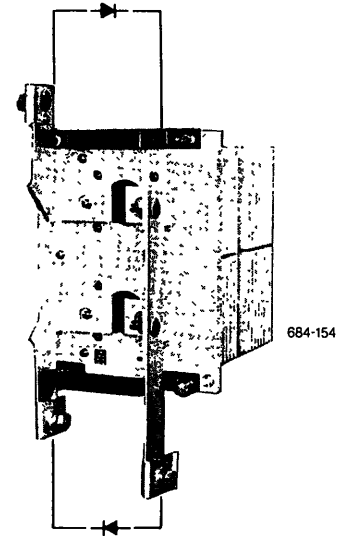

Check Points of Diode

## A5-2 TRANSISTOR MODULE

Measure the resistance across the module terminals with a volt-ohm meter. Use the meter by setting at  $\times 1\Omega$  range. The measured resistance should be within the reference value listed in Table 24.

Table 24 Transistor Module Resistances

Transistor Module Terminals		Reference Resistances	Abnormal Resistances	Transistor Module Terminals
VOM Terminal $\ominus$	VOM Terminal $\oplus$			
E	C	Several 10 ohms max	$0\Omega$ or $\infty$	
C	E	Several 100 kilohms min	$0\Omega$	
B (B1)	E	Several 10 ohms	Several kilohms	
E	B (B1)	Several 10 ohms	$0\Omega$ or $\infty$	

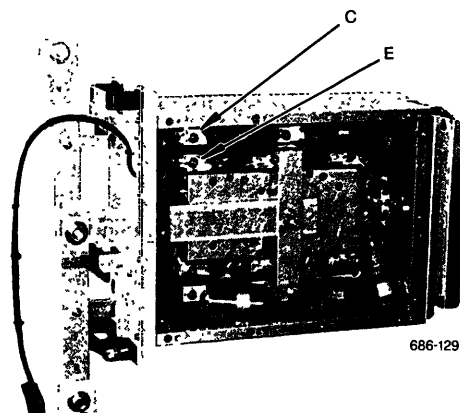

Check Points of Transistor Modules

## APPENDIX 6 PARTS REPLACEMENT

For checking or replacing parts, observe the following.

- Tag leads to insure correct reconnection before disconnecting the leads without marks.
- Tighten the parts mounting screws or lead terminal screws firmly. Even one loose screw may cause malfunction.

### A6-1 REPLACEMENT OF CONTROL PC BOARD

1. Remove the connectors 1CN, 5CN, 6CN, and 7CN by the lead lock. To remove the lead lock, press the top of the locking clip to release from the header and pull out.

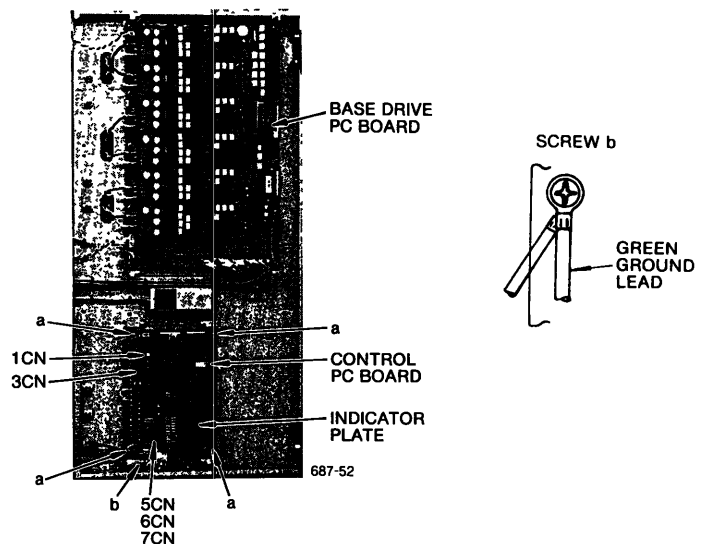
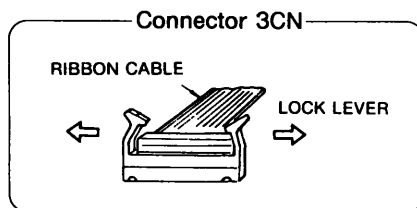
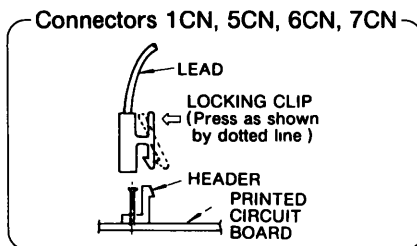

Fig. 33 Control PC Board

2. Remove the connector 3CN. Open the lock lever, and the connector is released.
3. Remove four screws (a) and a ground lead screw (b) to remove the control PC board. Remove two circuit board supports (c).
4. Take off the control printed PC board and shield plate which is attached to the rear of the board.

### A6-2 REPLACEMENT OF BASE DRIVE PC BOARD

1. Remove the connectors 1CN to 8CN and leads connected to screw terminals B1, E1 to B6, and E6.
2. Remove 17 mounting screws (a) and ground lead screw (b).

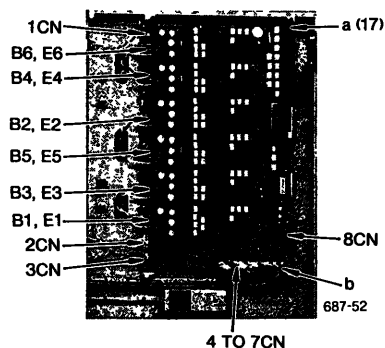

Fig. 34 Base Drive PC Board

### A6-3 REPLACEMENT OF DIODE

#### Removing Diode Power Module from Panel Rack

1. Loosen the 3 busbar connecting nuts and the 4 diode power module mounting screws, Fig. 35 (a).
2. Carefully take out the diode power module, Fig. 35 (b) and (c).

#### Removing Diode from Diode Power Module

1. Loosen the 4 fin fastening nuts by 1/4 turn with box wrench, respectively, and remove the flat spring and the fin. See Fig. 35 (d).
2. Remove the busbar after loosening the busbar connecting bolts and the mounting screws, Fig. 35 (c), (d) and (e).

#### Mounting

1. Clean each contact surface of diode, busbar and fin, and apply thermal compound "JOINTAL Z" (Nippon Light Metal Co., Ltd.), or equivalent compound, to each surface.
2. After mounting the busbar, confirming the diode polarity, align the fin positioning pin with the diode positioning hole. See Fig. 35 (e).
3. Finger tighten the 4 fin fastening nuts, keeping the flat spring parallel to the fin.
4. Using a box wrench, carefully tighten each of the 4 fin fastening nuts, in turn, 1/4 turn (3 times); then complete the tightening by 1/8 turns.
5. The procedure for mounting the diode power module is the reverse of those followed for removing the module.

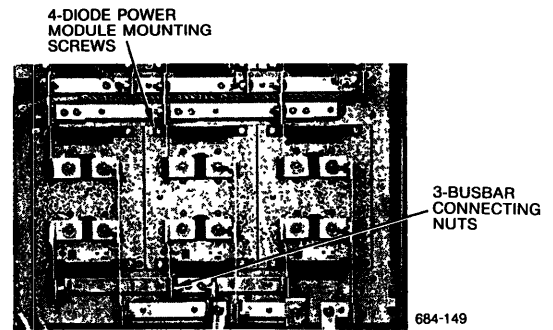

(a) With Diode Power Module Installed

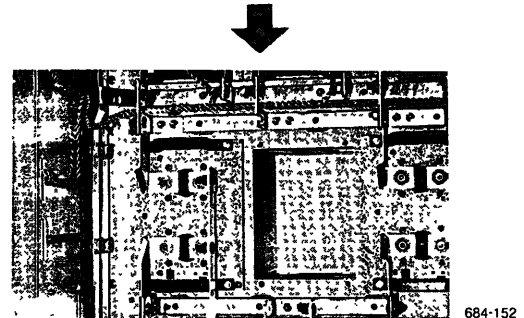

(b) With Diode Power Module Removed

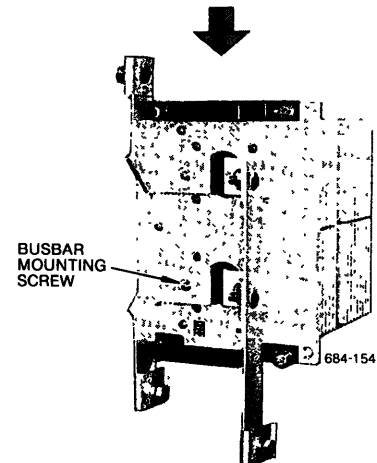

(c) Diode Power Module Configuration

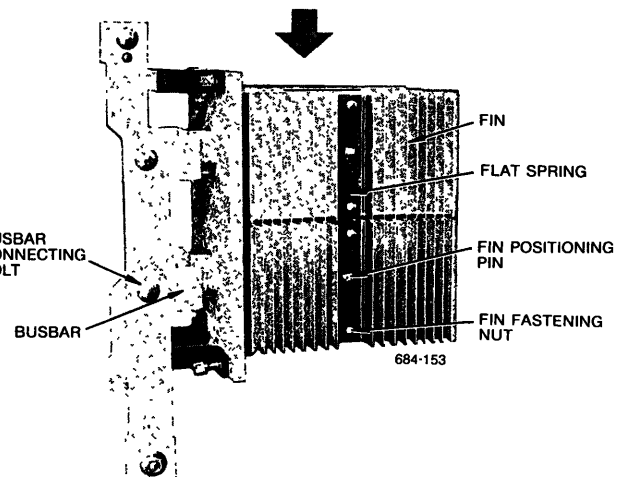

(d) Side View of Diode Power Module

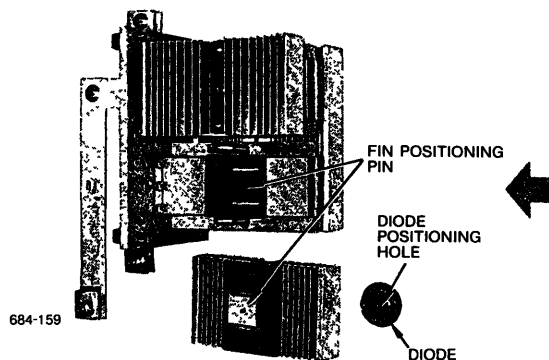

(e) With Diode Removed

Fig. 35 Removing Diode Power Module and Diode

## A6-4 REPLACEMENT OF TRANSISTOR MODULE

### Removing Transistor Power Module from Panel Rack

1. Pull out the connector for transistor emitter and base from the base drive sub-printed circuit board.
2. Loosen the 3 busbar connecting nuts and the 4 transistor power module mounting screws, Fig. 36 (a).
3. Carefully take out the transistor power module, Fig. 36 (b) and (c).

### Removing Transistor Module from Transistor Power Module

1. Remove the 10 side cover mounting screws of the transistor power module, Fig. 36 (d).
2. Remove the 10 busbar connecting screws, the 4 base wiring screws and the 4 printed circuit board mounting screws.
3. Take out the transistor module after loosening the 4 transistor module mounting screws, Fig. 36 (e).

### Mounting

1. Clean each contact surface of transistor module and fin, and apply thermal compound "JOINTAL Z" (Nippon Light Metal Co., Ltd.), or equivalent compound, to the base surface of the transistor module.
2. Mount the transistor module on the fin using  $25 \pm 5$  kgf-cm ( $2.54 \pm 0.5$  Nm) of fastening torque.
3. The procedures for mounting the transistor power module is the reverse of those followed for removing the module.

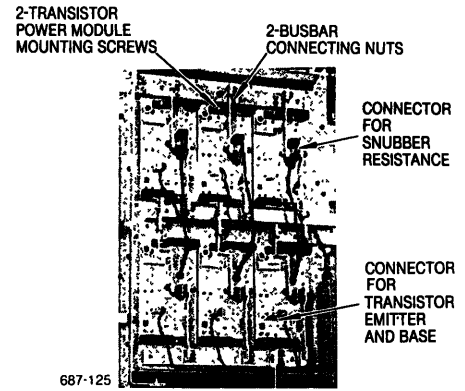

(a) With Transistor Power Module Installed

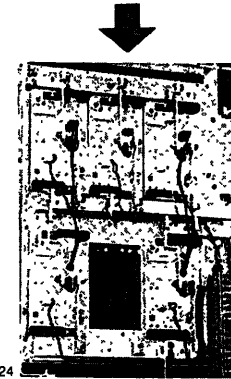

(b) With Transistor Power Module Removed

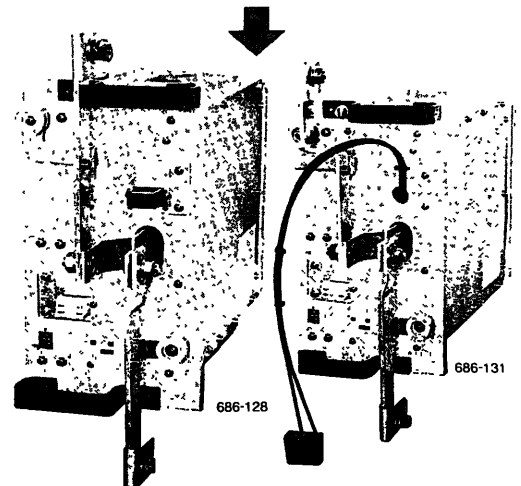

Negative Power Module (Upper) Positive Power Module (Lower)

(c) Transistor Power Module Configuration

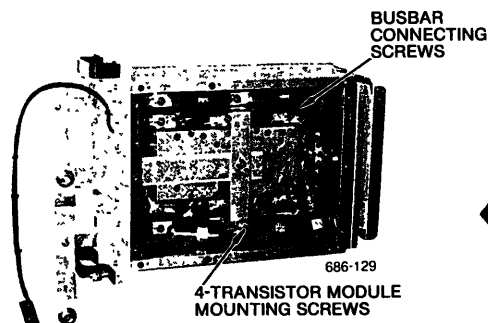

(e) With Side Cover Removed

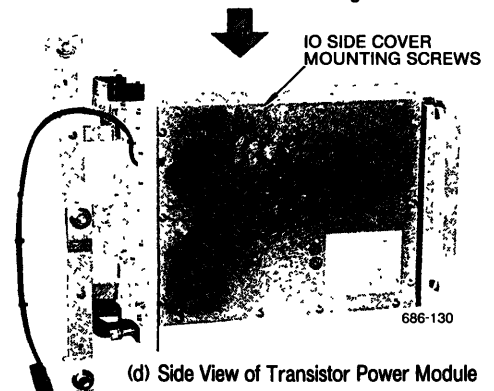

(d) Side View of Transistor Power Module

Fig. 36 Removing Transistor Power Module and Transistor Module

### A6-5 REPLACEMENT OF MAIN CIRCUIT FUSE

If the main circuit fuse is blown, fuse rod comes out.  
Remove main circuit fuse mounting screws and replace the blown fuse.

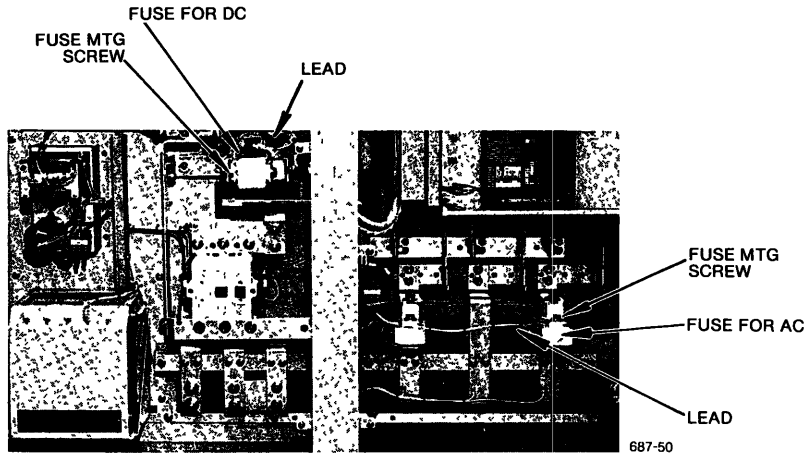

Fig. 37 Main Circuit Fuse.

### A6-6 REPLACEMENT OF COOLING FAN

The cooling fan for internal air circulation is incorporated.  
Replace the fan after approximately 20,000 hours of cumulative operation.

1. After removing the control PC and base drive PC boards as outlined in par. A6-1 and A6-2, remove two fan power leads.
2. Loosen four fan mounting screws and take off the fan unit.

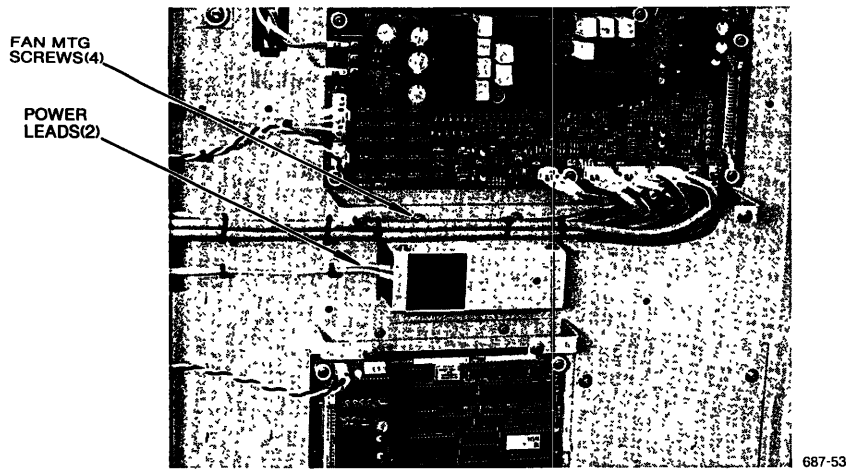

Fig. 38 Cooling Fan Assembly.

## APPENDIX 7 RENEWAL PARTS

As insurance against costly downtime, it is strongly recommended that renewal parts to be kept on hand in accordance with the table below. When ordering renewal parts, please specify to Yaskawa Electric office or representative with: Parts Name, Parts Code No. and Quantity.

Table 25 Renewal Parts

Parts Name	VS-616HII CIMR-□□	Type	Code No.	Qty	Remarks
Transistor Module*	H220B	QM300HA-2H	STR000269	36	1000V, 300A
	H300B	QM400HA1-2H	STR000249	36	1000V, 400A
Diode	H220B to H300B	400QD21	SID000271	6	1200V, 400A
Fuse	H220B	CS5F-800	FU000687	2	800A at AC side
		CS10F-800-P	FU000804	1	800A at DC side
	H300B	CS5F-1000-P	FU000802	2	1000A at AC side
		CS10F-1000-P	FU000801	1	1000A at DC side
Control PC Board*	H220B to H300B	JPAC-C237·□□□†	ETC50766X-S□□□XX†	1	—
Base Drive Board	H220B to H300B	JPAC-C272	ETC00801X	1	—
Fan Unit	H220B to H300B	—	EUX00156X	1	Roof fan
Fan	H220B to H300B	4715PS-22T·B30-07	FAN000121	1	Internal circulation

\*Transistor power module consists of 6 transistor modules connected in parallel  
Transistor modules are replaced as a set of 6 The 6 spare modules must have the same number or letter of characteristics rank which is stamped on the module surface

□□□ of the control PC board model name shows the type of function  
Spare board should have the same model name suffix as that of the board in use

†XX of Code No. for the control PC board indicates the revision number of the control PC board  
New board should have the same code suffix number or larger than that of the board being replaced

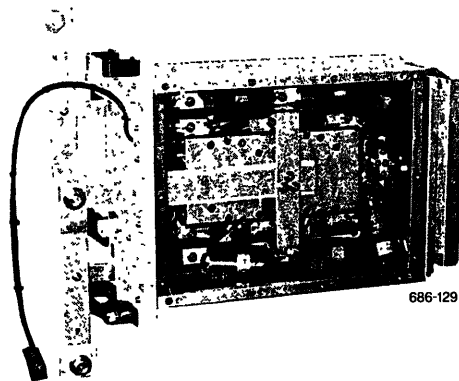

Transistor Power Module



(QM300HA-2H)

Transistor Module



*A Better Tomorrow for Industry through Automation*

**YASKAWA Electric Mfg. Co., Ltd.**

**TOKYO OFFICE** Ohtemachi Bldg, 1-6-1 Ohtemachi, Chiyoda-ku, Tokyo, 100 Japan  
Phone (03) 3284-9111, -9145 Telex YASKAWA J33530 Fax (03) 3284-9034

**SEOUL OFFICE** Seoul Center Bldg, 91-1, So Kong-Dong, Chung-Ku, Seoul, Korea  
Phone (02) 776-7844 Fax (02) 753-2639

**SINGAPORE OFFICE** CPF Bldg, 79 Robinson Road No 24-03, Singapore 0106  
Phone 2217530 Telex (87) 24890 YASKAWA RS Fax (65) 224-5854

**TAIPEI OFFICE** Union Commercial Bldg, 137, Nanking East Road, Sec 2, Taipei, Taiwan  
Phone (02) 507-7065, -7732 Fax (02) 506-3837

**YASKAWA ELECTRIC AMERICA, INC.: SUBSIDIARY**

**Chicago Office (Head Office)** 3160 MacArthur Blvd, Northbrook, Illinois 60062-1917, U S A  
Phone (708) 291-2340, 291-2348 Telex (230) 270197 YSKW YSNC NBRK Fax (708) 498-2430, 480-9731

**Los Angeles Office** 7341 Lincoln Way, Garden Grove, California 92641, U S A  
Phone (714) 894-5911 Telex (230) 678396 YASKAWAUS TSTN Fax (714) 894-3258

**New Jersey Office** 30 Two Bridges Road, Fairfield, New Jersey 07006, U S A  
Phone (201) 575-5940 Fax (201) 575-5947

**YASKAWA ELECTRIC EUROPE GmbH: SUBSIDIARY**  
Niederhochstadter Straße 71-73, W 6242 Kronberg-Oberhöchstadt, Germany  
Phone (06173) 640071, 640072, 640073 Telex 415660 YASE D Fax (06173) 68421

**YASKAWA ELETRICO DO BRASIL COMERCIO LTDA.: SUBSIDIARY**  
Av Brng Faria Lima, 1664-cj 721/724, Pinheiros, São Paulo-SP, Brasil CEP-01452  
Phone (011) 813-3933, 813-3694 Telex (011) 82869 YSKW BR Fax (011) 815-8795

*Due to ongoing product modification/improvement, data subject to change without notice.*